



KANE988

Industrial Flue Gas Analyser

KANE LINK



CONTENTS

Page No.

KANE988 OVERVIEW	4-5
ANALYSER FEATURES AND KEYPAD	6-9
KEYPAD BUTTONS	7
ANALYSER LAYOUT	8
BACK OF ANALYSER & PROBE	9
BATTERIES	10
BATTERY TYPE	10
REPLACING BATTERIES	10
TIME AND DATE	10
CHARGING NIMH BATTERIES	10
BATTERY DISPOSAL	10
GENERAL SAFETY	11
FIRST TIME USE	12
GENERAL OPERATING PRINCIPLE	12
USER INTERFACE	13
LOGGING DATA	13
PRINTING DATA	13
HOME MENU	14
MEASUREMENT	14
SETTINGS	15
REPORTS	16
ON SCREEN TRENDS	17
STATUS	18
SETUP	19
TOOLS	20
USING YOUR ANALYSER	21

MEASUREMENT MENU	22-28
FLUE GAS	23
PRESSURE & TEMP	24
AIRFLOW	24
DTHA2 SCREEN	24
PITOT SCREEN	24
TIMED LOGGING	25
TEST RUNNING	25
AVERAGE TEST	26
FIND MIDSTREAM	26
STABILISING	26
TEST RUNNING	26
TIGHTNESS TEST	27
CHOOSE LET-BY	27
LET-BY RUNNING	27
START STABILISATION	28
STABILISATION RUNNING	28
START TIGHTNESS TEST	28
TIGHTNESS TEST RUNNING	28
PRESSURE MEASUREMENT GOOD PRACTICE	29
MEASURING FLUE GASES	30
TAKING A PRESSURE READING	31
TAKING A FLOW READING PITOT	31
REGULAR CHECKS DURING SAMPLING	31
NORMAL SHUTDOWN SEQUENCE	32
PRINTOUTS	33-34
WATER TRAP MAINTANENCE	35-36
KANE  LINK - ADDING DEVICES	37-38
SPECIFICATIONS	39-40
EU DECLARATION	41
COLD WEATHER PRECAUTIONS	42
WELCOME TO KANE CARE	43-46
ANALYSER RECYCLING	47

KANE988 OVERVIEW

Your KANE988 combustion analyser uses up to 6 electrochemical sensors and our proprietary NDIR 3 gas detection bench to measure up to 8 gases and 9 sensors.

Your KANE988 has a colour graphical display and intuitive keypad to provide clear information and simple operation.

Your KANE988 is independently certified to EN50379 parts 1-3 by TUV.

Your KANE988 measures (sensor dependent):

- Carbon Monoxide (CO)
- Oxygen (O₂)
- Carbon Dioxide (CO₂)
- Nitric Oxide (NO)
- Nitrogen Dioxide (NO₂)
- Sulphur Dioxide (SO₂)
- Hydrogen Sulphide (H₂S)
- Hydrocarbons (HC)
- Pressure
- Differential Pressure
- Temperature
- Differential Temperature

Your KANE988 also calculates (sensor dependent):

- Nitrogen Oxides (NO_x)
- CO/CO₂ ratio
- Combustion Efficiency
- Losses
- Excess Air
- Poison Index (Pi)
- Airflow Pitot tube

Your KANE988 has an integral protective rubber cover and easy fit accessory clip on rear above the battery compartment.

Your KANE988 flow detector system automatically protects your analyser if a blockage is detected in the sampling system.

Your KANE988 prints test results using an optional infrared printer or wirelessly sends test results to the KANE LIVE App.

MEMORY

Your KANE988 stores:

- Combustion logs = 178
- Pressure/Temp logs = 178
- Airflow logs = 89
- DTHA2 logs = 89
- Tightness logs = 146
- Average logs = 117
- Timed Logs = 2 * 1440

You can enter 2 lines of 24 characters to personalise your test results.

KANE LINK

You can wirelessly connect optional KANE LINK devices to your analyser. When connected, they stay connected until you use KANE LINK to remove them.

When powered on, KANE LINK devices replace or add measurements to your analyser.

See page 37 to add or remove optional KANE LINK devices.

CO PROTECTION AND AUTO RANGE









Your KANE988 has an electrochemical CO sensor measuring to 10,000ppm and an NDIR CO sensor measuring to 100,000ppm / 10%.

Above 10,000ppm the NDIR sensor automatically manages CO to 100,000ppm / 10% while the electrochemical CO sensor is protected by the over range protection pump.

ANALYSER FEATURES AND KEYPAD



KEYPAD BUTTONS

ICON	DESCRIPTION
 PLAY / PAUSE	Pump On / Off
 PRINT F1	Short press to print a report - Analyser offers destination choice when wireless & irda fitted
 HOME	Return to home screen
 STORES / F2	Short press to Store / F2
 UP	Short press to scroll up
 DOWN	Short press to scroll down
 BACK / CANCEL	BACK / CANCEL
 OK / ENTER	OK / ENTER

ANALYSER LAYOUT

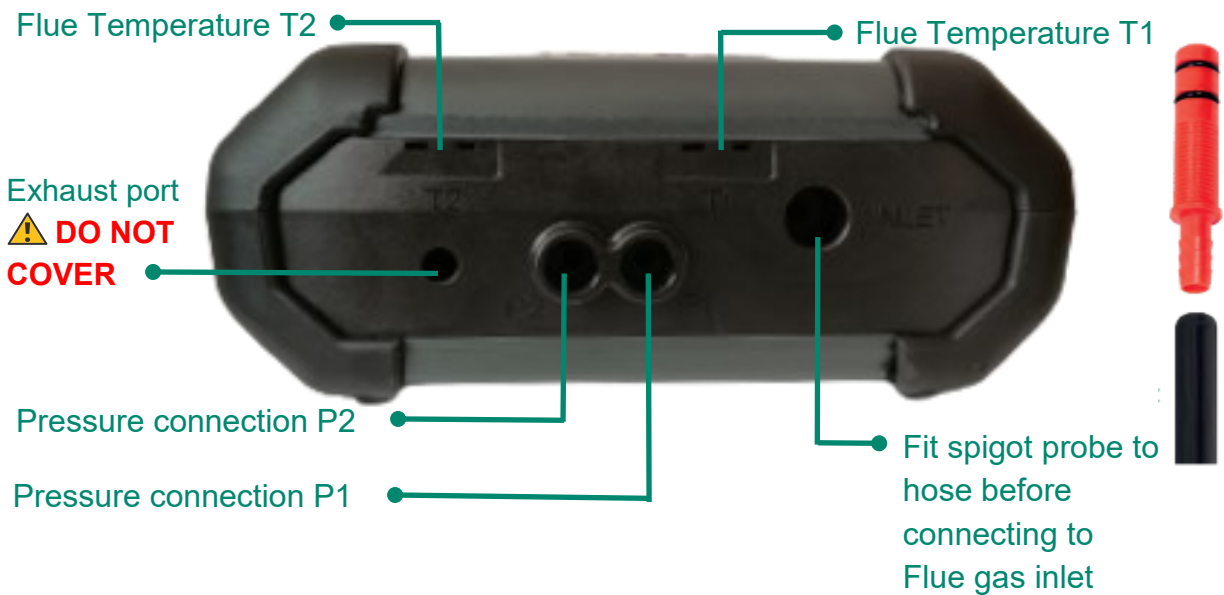

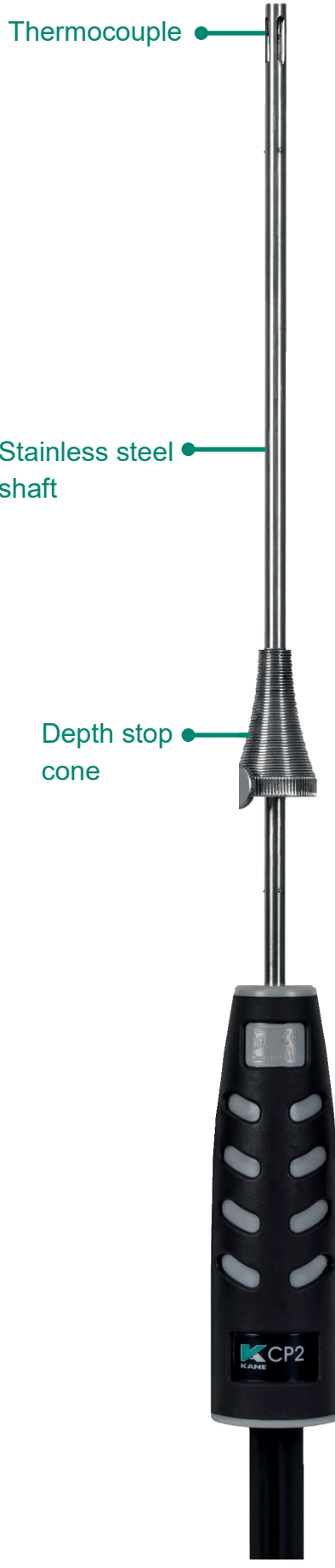

Thermocouple

Stainless steel shaft

Depth stop cone



Kane International,
Kane House, 11
Bessemer Rd, Welwyn
Garden City, AL7 1GF

CO	NO	O ₂	SO ₂	NO _x	H ₂ S	IRCO	IRHC	IRCO2
----	----	----------------	-----------------	-----------------	------------------	------	------	-------

Battery: 6 x AA NiMH

Conforms to
EN50379-1, 2 & 3

FCO id: 80281452
CI: 314748L652

CE UK

Gas exhaust ports



Thermocouple Wire

BATTERIES

BATTERY TYPE

Your analyser uses rechargeable Nickel Metal Hydride (NiMH) batteries. Using other battery types may void your analyser warranty.



Although you can use Alkaline batteries do not charge your analyser with Alkaline batteries fitted.

Do not mix NiMH cells with different capacities or from different manufacturers - All batteries must be identical.

REPLACING BATTERIES

Turn over your analyser & remove battery compartment cover.
Fit 6 x NiMH "AA" rechargeable batteries with correct battery polarity.
Replace battery compartment cover.

TIME AND DATE

After changing batteries reset your analyser time & date.

CHARGING NiMH BATTERIES

Your first charge should be for 8 hours - Thereafter NiMH batteries can be topped up any time, even for short periods.

BATTERY DISPOSAL

Always dispose of depleted batteries using approved disposal methods that protect the environment.

GENERAL SAFETY

SAFETY WARNING

Your analyser extracts combustion gases that may be toxic in relatively low concentrations.

These gases are exhausted from the back and bottom of the analyser.

This analyser must only be used in well-ventilated locations by trained and competent persons after due consideration of all potential hazards.

Portable gas detectors should conduct “bump” tests before relying on units to verify atmospheres are free from hazards.

A “bump” test checks an analyser works within acceptable limits by briefly exposing it to known gas mixtures to change output of sensors present.

NOTE: This is different from a calibration where your analyser is exposed to known gas mixtures but allowed to settle to a steady figure with readings adjusted to the test gas concentration.

Protection Against Electric Shock - (In accordance with EN 61010-1:2010).

This analyser is designed as Class III equipment and should only be connected to SELV (Safety Extra Low Voltage) circuits.

The battery charger is designated as:

- Class II equipment
- Installation category II
- Pollution degree 2
- Indoor use only
- Altitude to 2000m
- Ambient temperature 0°C-40°C
- Maximum relative humidity 80% for temperatures up to 31°C decreasing linearly to 50%RH at 40°C
- Mains supply fluctuations not to exceed 10% of the nominal voltage

FIRST TIME USE

Charge your analyser batteries for 8 hours - an overnight charge should be sufficient for an average 8-hour day.

Take time to read this manual fully and be aware your analyser configuration may not support all features explained in this manual.

Before use set up your analyser to your requirements.

GENERAL OPERATING PRINCIPLE

After powering on your analyser, choose tasks to perform using MENU.

Most tests can be made with little user activity.

Your analyser status bar displays useful information.

USER INTERFACE

Navigate via the 5 button control panel - press HOME to return to HOME MENU:





LOGGING DATA

Press STORE key  until display shows LOG STORED.

PRINTING DATA

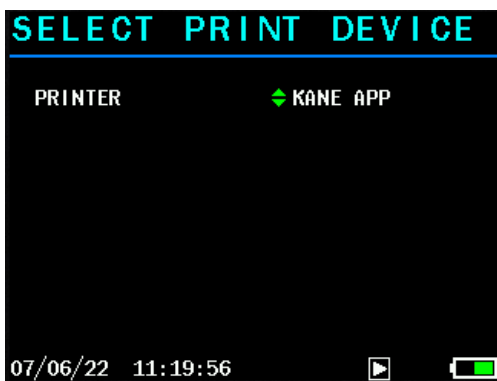
Press PRINT key  to select print destination.



Press ENTER key  - display changes to show print progress.

To print logged data:
Select LOG ON in REPORTS menu

Press PRINT key  or select desired test from MEASUREMENT MENU and use View Logs

Select LOG NO and press PRINT key 

HOME MENU

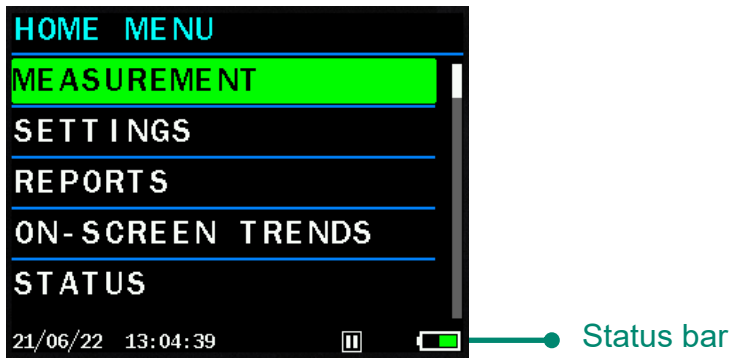

Press **HOME** to display HOME **MENU** list.

MENU ITEM	COMMENTS
MEASUREMENT	Menu to select task to perform
SETTINGS	Change date, time, measurement parameters, alarms etc
REPORTS	Configure logging parameters and view stored data
ON-SCREEN TRENDS	Configure and display trend information
STATUS	Current instrument status, software version etc
SETUP	Menu to change analyser settings
TOOLS	Manual air and pressure zero, mid-stream finder tool
SERVICE	Reserved

NOTE: Your analyser STATUS bar displays current time, date and battery status.

Check time & date are correct as they can only be changed if you have no stored logs in Memory to protect integrity of stored data.

MEASUREMENT

Start measurements and tests

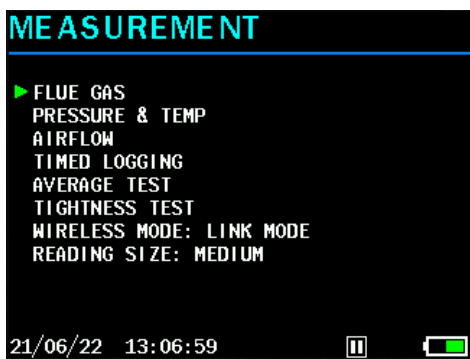

See page 22 for details

SETTINGS

Enter changes.



MENU ITEM	OPTIONS / COMMENTS
DATE / TIME	Set date and time - NOTE: Can only change if all logs in memory are cleared
FUEL TYPE	Select desired option via UP / DOWN and OK to confirm
EFFICIENCY	Select desired option via UP / DOWN and OK to confirm
GAS UNIT	Select desired units required for measured gas parameter
TEMPERATURE	Select desired option via UP / DOWN and OK to confirm
PRESSURE	Select desired option via UP / DOWN and OK to confirm
REFERENCE O2	Set reference O2 for CO and NO sensor independently
ALARMS	Toxic Gas Alarm YES / NO Battery Low Alarm YES / NO Watertrap Check Warning YES / NO Excessive CO Warning YES / NO
CONVERSION FACTORS	Select desired Pitot factor

REPORTS

Create, edit and remove reports



MENU ITEM	OPTIONS / COMMENTS
VIEW COMB. REPORTS	View reports
VIEW PRS & TEMP REPORTS	View reports
VIEW AIRFLOW REPORTS	View reports
VIEW DTHA2 REPORTS	View reports
DELETE REPORTS	Select by report type or all

ON-SCREEN TRENDS

Create and display custom measurement trends

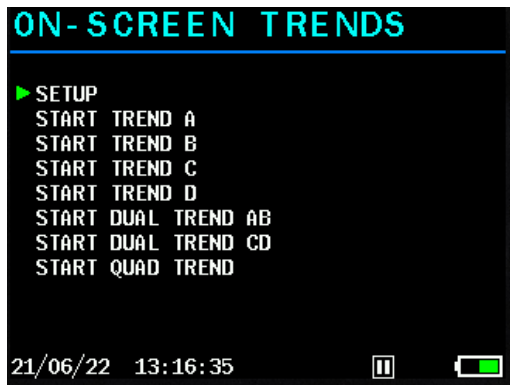



MENU ITEM	OPTIONS / COMMENTS
SETUP	Set: SAMPLING INTERVAL TREND A Parameter TREND B Parameter TREND C Parameter TREND D Parameter
START TREND A	Start
START TREND B	Start
START TREND C	Start
START TREND D	Start
START DUAL TREND AB	Start
START DUAL TREND CD	Start
START QUAD TREND	Start

STATUS

View current configuration and setup

STATUS 1/5

KANE988	SW00244 V1.0.0rc1
SERIAL No.	9880001764
ASSET No.	None
CAL OVERDUE	8148d
BATTERY	54%
WIRELESS	KANE LINK

21/06/22 13:35:00  



OPERATOR 2/5

OPERATOR	Your Name
COMPANY	Your Company Name
ADDR LINE 1	Address line 1
ADDR LINE 2	Address line 2
CITY/TOWN	City/Town
POST CODE	Postcode
TELEPHONE	Company Mobile
MOBILE	Company Telephone
WEB/EMAIL	Company Website

21/06/22 13:20:04  



SENSORS FITTED 3/5

O2	25 %
CO	100 ppm
H2	-N/F-
NO	1000 ppm
NO2	200 ppm
S02	2000 ppm
H2S	-N/F-
CO2	-N/F-
CO	-N/F-
HC	-N/F-

21/06/22 13:20:55  

COMBUSTION 4/5

AUTO ZERO	YES
MAIN PURGE DURATION	1m 30s
MAIN PURGE INTERVAL	3h
REFERENCE O2	0.3%
SIMULATED NO2	5%
EFFICIENCY	GROSS
FUEL TYPE	Natural Gas
CO ALARM LEVEL	400ppm

21/06/22 13:21:27  

REPORTS 5/5

NO. COMBUSTION LOGS	0
AUTO LOG INTERVAL	10s
AUTO LOG	NO

21/06/22 13:22:08  

SETUP

Make further changes

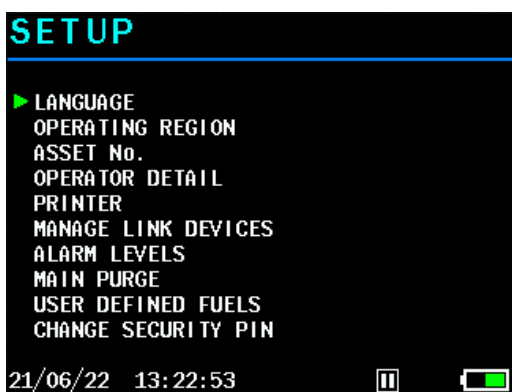

MENU ITEM	OPTIONS / COMMENTS
LANGUAGE	Select analyser operating language
OPERATING REGION	Select fuel table country or region
ASSET NO.	Enter equipment asset number
OPERATION DETAIL	Enter operator / owner information
PRINTER	Select IR printer type
MANAGE LINK DEVICES	Add or remove KANE LINK devices
ALARM LEVELS	Set alarm trigger levels for each gas sensor -
MAIN PURGE	Set: MAIN PURGE DURATION Time in seconds MAIN PURGE INTERVAL Time in minutes AUTO ZERO YES/NO
USER DEFINED FUELS	Add custom fuel types
CHANGE SECURITY PIN	Set to stop changes without PIN code entry

TOOLS

For more accurate measurements

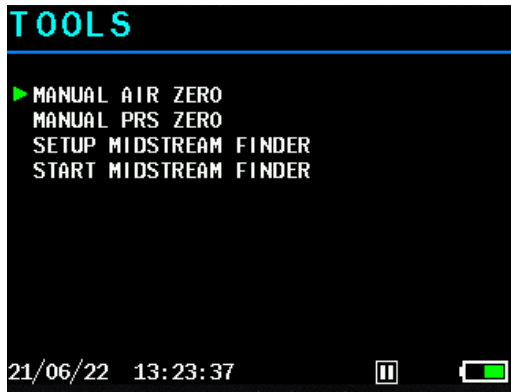

MENU ITEMS	OPTIONS / COMMENTS
MANUAL AIR ZERO	Manually trigger Air Zero purge. ⚠ Always purge in fresh outdoor air
MANUAL PRS ZERO	Manually trigger zero calibration for pressure sensor - ⚠ Disconnect all pressure hoses first
SETUP MIDSTREAM FINDER	Setup MIDSTREAM FINDER Tool parameters, temperature and pressure limits
START MIDSTREAM FINDER	Start MIDSTREAM Finder Tool

SERVICE

Restricted area for authorized personnel only.

USING YOUR ANALYSER

CHECK BEFORE SWITCH-ON:

1. Particle and water stop filter are dry and clean
2. Water trap and probe line are empty of water
3. Water trap is correctly fitted and instrument upright
4. All hoses connections, etc, are properly made
5. Flue temperature is connected
6. Analyser & probe will sample fresh outdoor air

Power ON instrument by pressing  to start automatic calibration count down.

AUTOMATIC CALIBRATION

During automatic calibration analyser samples fresh air to zero toxic sensors and set oxygen sensor to 20.95%.

After power on your analyser displays identity, software version and serial number.

“ ANALYSER PURGING 90 secs” countdown appears on display.

Calibration time counts down in seconds to zero and can be changed to 90, 120, 180 or 300 seconds.

NOTE:- 180 seconds is recommended to allow sensors to fully stabilise
- anything less may result in toxic and oxygen sensor drift.

MEASUREMENT MENU

Start measurements and tests

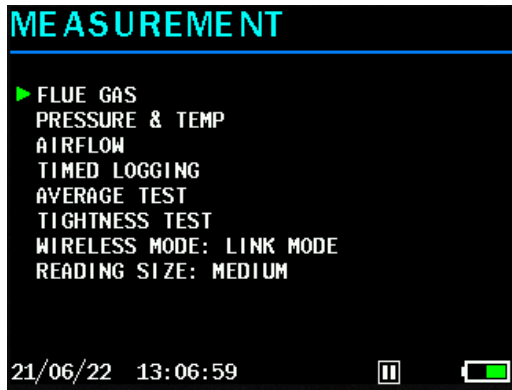

MENU ITEM	OPTIONS / COMMENTS
WIRELESS MODE	Choose between KANE  LINK or KANE APP modes
READING SIZE	Choose text size for task screens

NOTE:- Ensure analyser displays correct date & time before making measurement.

FLUE GAS

Begins measurement process - flue gas measurements are displayed over 3 pages.

Navigate via ▲▼ buttons on control panel.

FLUE Natural Gas Pg 1			
O2	20.76%	CO	0
CO2	0.00%	R	0.0000
Tf	19.8	DFT	745
Ti	- - -	XA	02++
TΔ	-0.5	Eg	- - - -
		BAT	54%
21/06/22 13:27:51			

FLUE Natural Gas Pg 2			
O2	20.76%	CO	0
CO2	0.00%	R	0.0000
DRY	02++	C/L	02++
WET	02++	LOS	02++
Ta	20.3	BP	1013.3
		BAT	54%
21/06/22 13:28:53			

FLUE Natural Gas Pg 3			
O2	20.76%	CO	0
CO2	0.00%	R	0.0000
NO	0	SO2	0
NO2	0	H2S	0
NOX	0	PI	- - - -
HC	0	BAT	54%
21/06/22 13:29:15			

PRESSURE & TEMP

Start pressure and temperature measurements

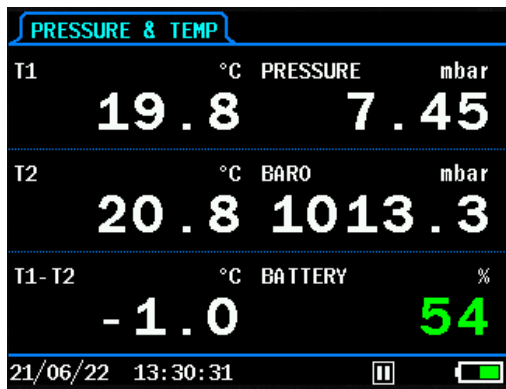

AIRFLOW

Screen defaults to Pilot measurement unless a KANE-DTHA2 is connected.

DTHA2 SCREEN

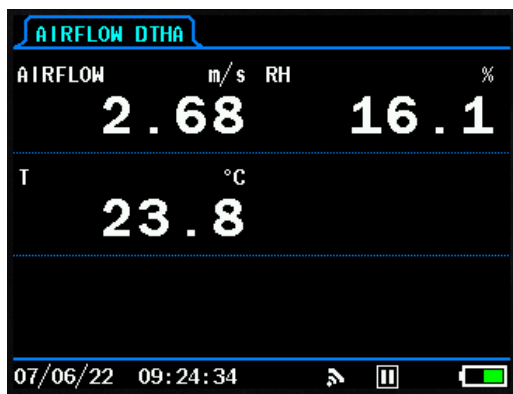

PITOT SCREEN

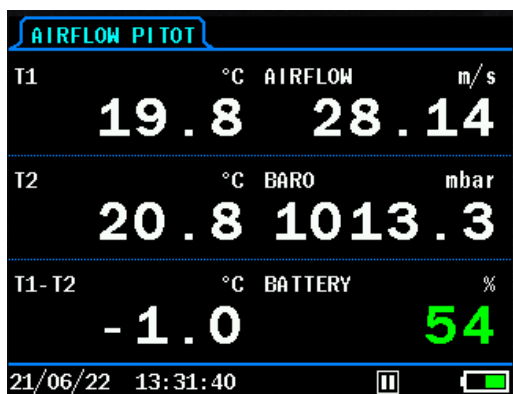

TIMED LOGGING

Configure and perform timed logs

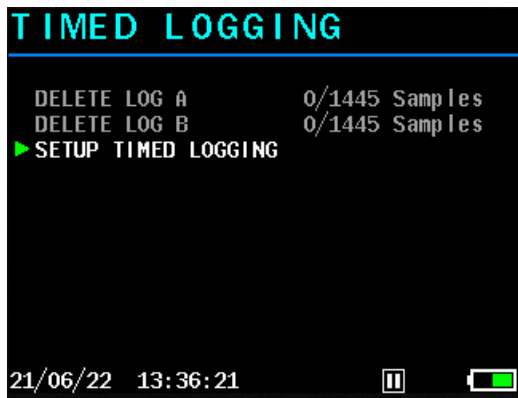

MENU ITEMS	OPTIONS / COMMENTS
MEASURE MODE	Choose required measurement parameters: FLUE GAS AIRFLOW PRESSURE & TEMP
DURATION	Choose test duration from 1 to 24 hours
INTERVAL	Choose sampling interval from 3 to 60 seconds
TOTAL SAMPLES	Indicates number of samples collected based on DURATION and INTERVAL settings
START TEST	Begin test

TEST RUNNING

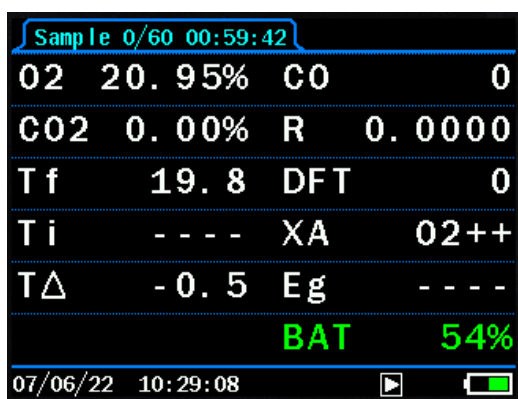

AVERAGE TEST

Configure and perform average tests



MENU ITEM	OPTIONS / COMMENTS
TEST ID	Enter unique ID for test or use automatically generated ID
DURATION	Choose test duration from 30 seconds to 30 minutes
FUEL TYPE	Select required fuel type
START TEST	Begin test

FIND MIDSTREAM

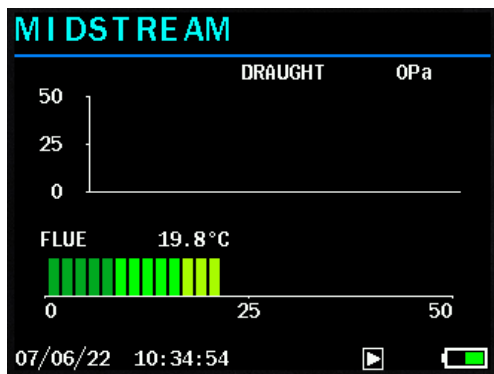

STABILISING

Stabilising			
O2	20.95%	CO2	0.00%
FLUE	19.8 °C	DRAUGHT	0 Pa
INLET	---- °C	LOSS	02++
T NET	-0.5 °C	Eff (G)	----
LAMBDA	02++	CO/CO2	0.0000
CO	0 ppm	CO	02++ mgm3
CO _n	02++ ppmN	CO	02++ mgkWh
NO	0 ppm	NOX	02++ mgm3
NOX _n	02++ ppmN	NOX	02++ mgkWh
		BARO	1013.3 mbar
AMBIENT	20.3 °C	BATTERY	54%
07/06/22 10:35:40			

TEST RUNNING

AVERAGE TEST 00:27 Test Gas			
O2	20.95%	CO2	0.00%
FLUE	19.8 °C	DRAUGHT	0 Pa
INLET	---- °C	LOSS	02++
T NET	-0.5 °C	Eff (G)	----
LAMBDA	02++	CO/CO2	0.0000
CO	0 ppm	CO	02++ mgm3
CO _n	02++ ppmN	CO	02++ mgkWh
NO	0 ppm	NOX	02++ mgm3
NOX _n	02++ ppmN	NOX	02++ mgkWh
		BARO	1013.3 mbar
AMBIENT	20.3 °C	BATTERY	54%
07/06/22 10:36:13			

TIGHTNESS TEST

Configure and perform tightness tests



Using black connectors, connect your manometer hose from appliance test point to analyser P1 input.

CHOOSE LET-BY (optional)



LET-BY RUNNING



START STABILISATION



STABILISATION RUNNING



START TIGHTNESS TEST



TIGHTNESS TEST RUNNING



PRESSURE MEASUREMENT GOOD PRACTICE



Before using your analyser to measure an appliance gas/air ratio valve, read appliance manufacturer instructions thoroughly. If in doubt, contact appliance manufacturer.

After adjusting a gas/air ratio valve O₂, CO₂ & CO/CO₂ ratio readings must be within appliance manufacturer specified limits.

MEASURING FLUE GASES

After countdown is finished and your analyser is correctly set up, put your flue probe into the appliance sampling point.

Place probe tip in the flue centre - use flue probe depth stop cone to set position.

With balanced flues, make sure probe is positioned far enough into the flue so no air can “back flush” into the probe.

SAFETY WARNING

Ensure your flue probe handle does not get hot!

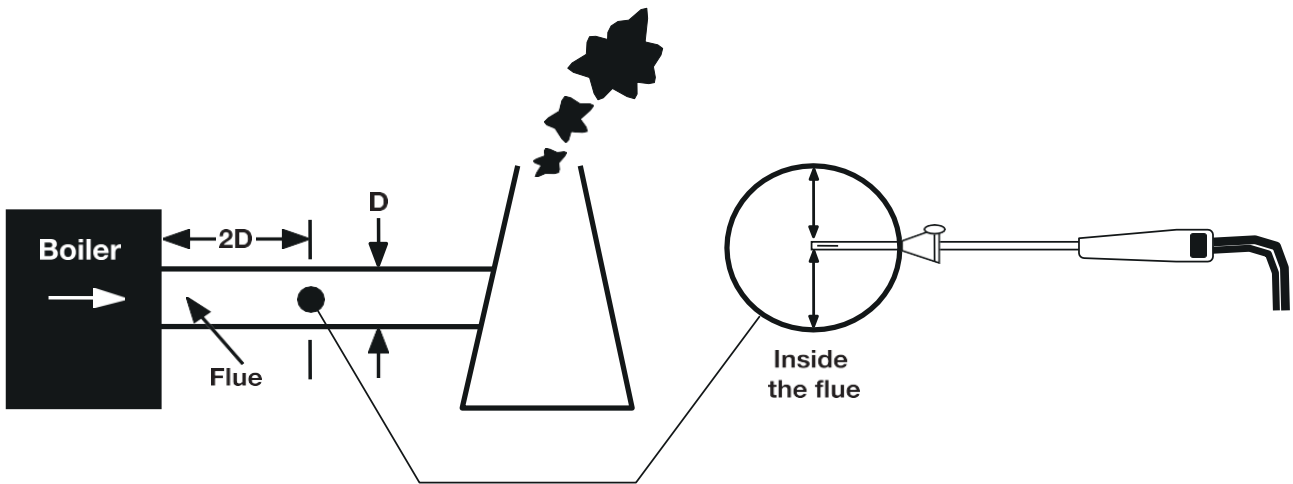

Do not exceed analyser operating specifications - In particular:

- Do not exceed flue probe maximum temperature depending on flue probe type
- Do not exceed analyser internal temperature operating range
- Do not put analyser on a hot surface
- Do not exceed analyser water trap levels
- Do not let analyser particle filter become dirty and blocked

Check readings are stable and within expected range.

TAKING A PRESSURE READING



**NEVER TAKE A PRESSURE READING WITHOUT KNOWING
MAXIMUM PRESSURE POTENTIALLY PRESENT.
THIS PRESSURE TRANSDUCER IS RATED AT 2 PSI.**

Flue draught measurements can be made at any time.

Connect the standard probe to analyser pressure port inlet then place probe in flue to display a pressure reading.

To perform a combustion and draught test a dual purpose probe is required, contact KANE International or an Authorised Distributor for details.

TAKING A FLOW READING - PITOT MEASUREMENT

In UNITS menu set pressure units to metres/sec (m/sec), the only choice available for flow measurements, and set pressure display to Pascal (Pa).

NOTE: Range limit for Pitot calculation is 15Pa to 4600P and 0.15mbar to 446mbar.

For accurate flow measurement flue gas temperature should also be Measured, If a flue temperature probe is not fitted analyser internal ambient measurement is used.

NOTE: Flue temperature must be between -10°C to +650°C.

REGULAR CHECKS DURING SAMPLING

Take care at all times not to exceed analyser operating specifications, in particular:

- Do not exceed flue probe maximum temperature
- Do not exceed analyser internal temperature
- Do not place analyser on a hot surface
- Keep analyser water trap vertical - water vapour condenses in probe line and can quickly fill analyser water trap
- Keep analyser in-line particle filter clean and dry

NORMAL SHUTDOWN SEQUENCE

DO THIS EVERY TIME YOU USE THE ANALYSER



Remove probe from flue - **TAKE CARE! PROBE WILL BE HOT** - and allow to cool naturally.

Allow analyser to purge in fresh air for at least three minutes or until all toxic sensor readings are below 10ppm.

Do not immerse probe in water as this will damage pump and sensors.

NOTES: It is good practice to hang probe hose vertically after sampling so condensate drains away.

PRINTOUTS

Average Test

```

Joe Bloggs
KANE International Ltd
KANE House
11 Bessemer Road
Welwyn Garden City
AL7 1GF
01707 375 550
0800 059 0800
joe.bloggs@kane.co.uk

KANE988
SERIAL No. 0151922091
S/W SW00244, V1.0.0rc1

AVERAGE TEST

LOG 3
TEST ID 20220621T110606L
DATE 21/06/22
TIME 11:07:17

O2 % 3.42
CO2 % 10.1
CO ppm 14
COn ppmN 14
CO mgm3 18
CO mgkWh 18
CO/CO2 0.0001
XS AIR % 19.51
DRAUGHT Pa 238
FLUE °C 40.6
INLET °C ----
T NET °C 17.0
CO LOSS % 0.0
DRY LOSS % 0.6
WET LOSS % 10.0
LOSS % 10.6
Eff (G) % 89.39
NO ppm 12
NOn ppmN 12
NO2 ppm 9
NO2n ppmN 9
NOXn ppmN 22
NOX mgm3 44
NOX mgkWh 44
SO2 ppm 16
SO2n ppmN 16
SO2 mgm3 47
SO2 mgkWh 47
H2S ppm 0
H2Sn ppmN 0
H2S mgm3 0
H2S mgkWh 0
-----
BARO mbar 1005.4
AMBIENT °C 23.6
BATTERY % 92
FUEL Natural Gas
REF O2 % 3.0
REF O2(NO)% 3.0

CUSTOMER
.....
.
.
.....

APPLIANCE
.....
.
.
.....

REFERENCE
.....
.
.
.....

```

Flue Gas Combustion Test

```

Joe Bloggs
KANE International Ltd
KANE House
11 Bessemer Road
Welwyn Garden City
AL7 1GF
01707 375 550
0800 059 0800
joe.bloggs@kane.co.uk

KANE988
SERIAL No. 0151922091
S/W SW00244, V1.0.0rc1

FLUE GAS

LOG 36
DATE 21/06/22
TIME 08:44:06

O2 % 0.00
CO2 % 8.8
CO ppm 404
COn ppmN 404
CO mgm3 505
CO mgkWh 0
CO/CO2 0.0046
XS AIR % 0.00
DRAUGHT Pa -1
FLUE °C ----
INLET °C ----
T NET °C ----
CO LOSS % 0.0
DRY LOSS % 0.0
WET LOSS % 0.0
LOSS % 0.0
Eff (G) ----
NO ppm 0
NOn ppmN 0
NO2 ppm 2
NO2n ppmN 2
NOXn ppmN 2
NOX mgm3 4
NOX mgkWh 0
SO2 ppm 10
SO2n ppmN 10
SO2 mgm3 29
SO2 mgkWh 0
H2S ppm 0
H2Sn ppmN 0
H2S mgm3 0
H2S mgkWh 0
-----
BARO mbar 1006.5
AMBIENT °C 22.1
BATTERY % 85
FUEL Test Gas
REF O2 % 0.0
REF O2(NO)% 0.0

CUSTOMER
.....
.
.
.....

APPLIANCE
.....
.
.
.....

REFERENCE
.....
.
.
.....

```

Humidity

```
Joe Bloggs
KANE International Ltd
KANE House
11 Bessemer Road
Welwyn Garden City
AL7 1GF
01707 375 550
0800 059 0800
joe.bloggs@kane.co.uk

KANE988
SERIAL No. 0151922091
S/W SW00244, V1.0.0rc1

HUMIDITY

LOG 3
DATE 17/06/22
TIME 10:25:20

AIRFLOW m/s 0.00
RH % 42.0
T °C 21.0
-----
BARO mbar 1010.4
AMBIENT °C 24.4
BATTERY % 93
FUEL Natural Gas
REF O2 % 3.0
REF O2(NO)% 3.0

CUSTOMER
.....
.
.
.
.....

APPLIANCE
.....
.
.
.
.....

REFERENCE
.....
.
.
.
.....
```

Airflow

```
Joe Bloggs
KANE International Ltd
KANE House
11 Bessemer Road
Welwyn Garden City
AL7 1GF
01707 375 550
0800 059 0800
joe.bloggs@kane.co.uk

KANE988
SERIAL No. 0151922091
S/W SW00244, V1.0.0rc1

AIRFLOW

LOG 3
DATE 21/06/22
TIME 11:16:47

AIRFLOW m/s 48.38
BARO mbar 1005.5
T1 °C 73.9
T2 °C 50.5
T NET °C 23.4
-----
BARO mbar 1005.5
AMBIENT °C 24.5
BATTERY % 93
FUEL Test Gas
REF O2 % 0.0
REF O2(NO)% 0.0

CUSTOMER
.....
.
.
.
.....

APPLIANCE
.....
.
.
.
.....

REFERENCE
.....
.
.
.
.....
```

Pressure & Temp

```
Joe Bloggs
KANE International Ltd
KANE House
11 Bessemer Road
Welwyn Garden City
AL7 1GF
01707 375 550
0800 059 0800
joe.bloggs@kane.co.uk

KANE988
SERIAL No. 0151922091
S/W SW00244, V1.0.0rc1

PRESSURE & TEMP

LOG 5
DATE 21/06/22
TIME 11:14:47

PRESSURE mbar 18.42
BARO mbar 1005.6
T1 °C 73.7
T2 °C 50.4
T NET °C 23.3
-----
BARO mbar 1005.6
AMBIENT °C 24.2
BATTERY % 94
FUEL Test Gas
REF O2 % 0.0
REF O2(NO)% 0.0

CUSTOMER
.....
.
.
.
.....

APPLIANCE
.....
.
.
.
.....

REFERENCE
.....
.
.
.
.....
```

Tightness Test

```
KANE988
SERIAL No. 0151922091
S/W SW00244, V1.0.0rc1
LOG 1
DATE 21/06/22
TIME 11:47:18

-----

LETBY TEST

PRS1 mbar 14.92
PRS2 mbar 15.29
LET BY MINS 1:00

TIGHTNESS TEST

PRS1 mbar 18.04
PRS2 mbar 18.34
DELTA mbar -0.29

STABILISN MINS 2:00
TIGHTNESS MINS 1:00
-----

CUSTOMER
.....
.
.
.
.....

APPLIANCE
.....
.
.
.
.....

REFERENCE
.....
.
.
.
.....
```

WATER TRAP MAINTANENCE

KANE988 Water Stop Technology

Your analyser has a water trap & particle filter to stop appliance flue gas water vapour & dust entering your analyser.

However, some boilers produce much higher volumes of water vapour which can affect your analyser.

Your analyser has a water stop filter with hydrophobic technology located inside the water trap to stop water vapour.

The water stop filter sits in a filter carrier located above the particle filter inside the water trap.

You must replace water stop & particle filters when wet, dirty or your analyser displays LOW FLOW.

To replace:

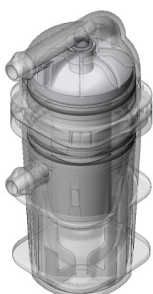

- 1) Carefully remove water trap from housing



- 2) Pull reservoir vertically from filter holder

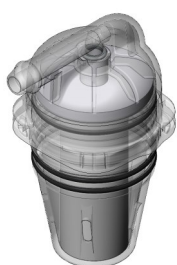

- 3) Rotate top part of filter housing 30° anti-clockwise



- 4) Pull particulate filter receiver vertically from water stop filter receiver

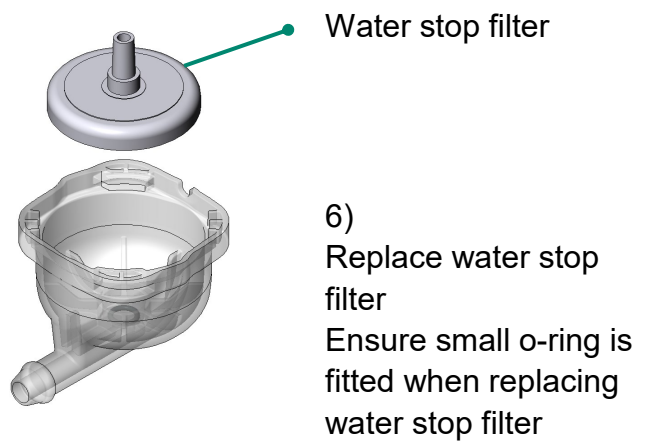
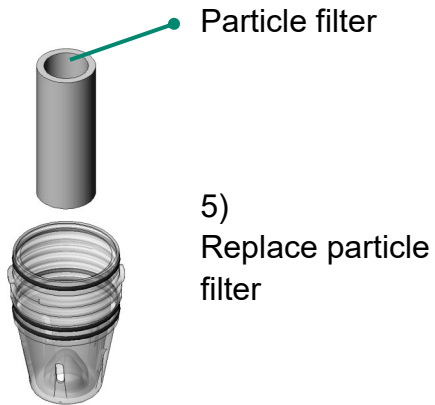

Replacement part numbers:

Water Stop filter: WSF2

Particle filter: PF2



Water trap: SM50675

KANE LINK WIRELESS MEASUREMENT AND DATA TRANSFER



You can wirelessly connect optional KANE LINK devices to your analyser.



Navigate to **MANAGE LINK DEVICES** in **SETUP MENU** - see page 19.

To wirelessly transfer data to a connected smart device running our KANE LIVE App, select App using 

To **ADD**, **REMOVE** and check **STATUS** of optional KANE LINK device select **LINK** using  &  buttons.

WPCP2 WIRELESS PIPE CLAMP

To add select then enter serial number using  &  buttons.



Enter serial number using  &  buttons - Each clamp serial number must be 10 digits long.

If longer use the last 10 digits, e.g, enter serial number below using last 10 digits: 2105094301



DTHA2 ANEMOMETER

To add your DTHA2 anemometer select DTHA2 using  &  buttons.

Enter serial number using  &  buttons - Each serial number must be 10 digits long.

If shorter enter 0's to make up to 10 - For example: Enter serial number 2001228 below as 0002001228.



Other KANE LINK devices can be paired - Contact KANE for more details

CO MONITOR

To add select a CO Monitor using ▲ & ← buttons.

Enter serial number using ▲ & ← buttons - Each serial number must be 10 digits long.

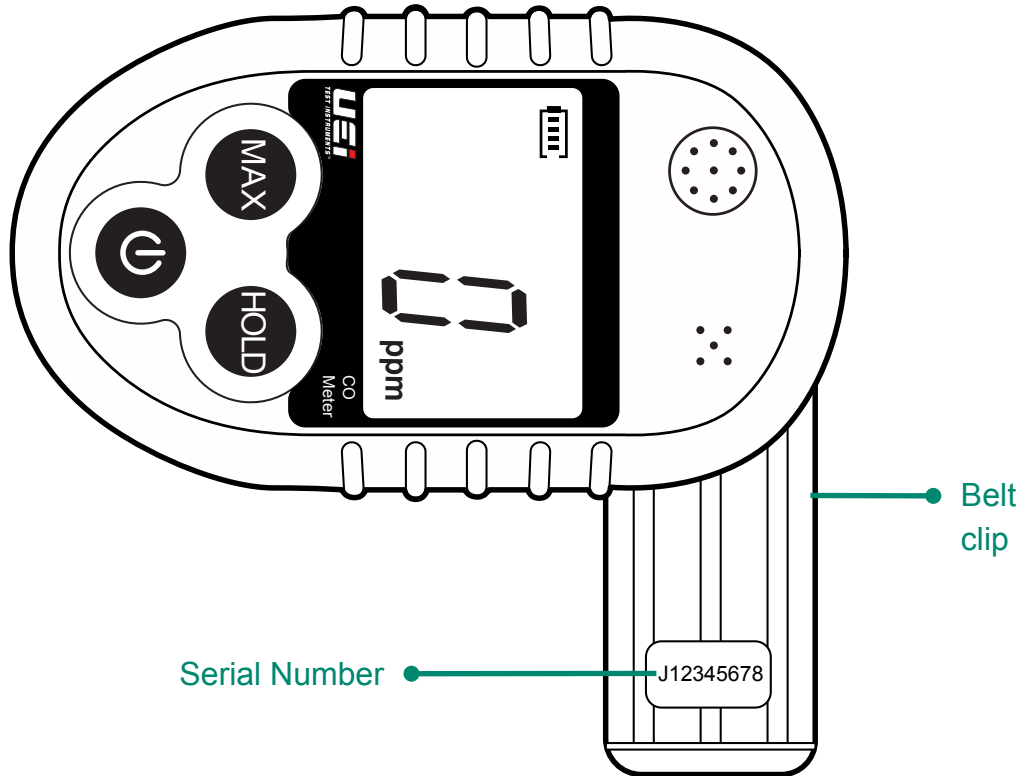

Use numeric part of serial number to pair your KANE LINK analyser.
KANE LINK requires a 10-digit serial number - If shorter, use 0's to make up to 10 digits of serial number.

For example: Enter serial number J12345678 above as 0012345678.

SPECIFICATIONS

PARAMETER	RESOLUTION	ACCURACY	RANGE
Temperature & Pressure Measurement			
Flue Temperature	0.1°C	±0.1°C ±0.3% reading	-50 - 1200°C With suitable probe
Inlet Temperature	0.1°C	±0.1°C ±0.3% reading	0 - 50°C
Pressure (Differential)	0.1mbar	±0.5% FSD full scale	±150mbar
Flue Gas Measurement *1			
Oxygen	0.1%	±0.3% Volume	0 - 25%
Carbon Monoxide (H2 Compensated)	1ppm	±5ppm<100ppm ±5%>400ppm - 2000ppm ±10%>2000ppm	0 - 10000ppm 10000 - 20000ppm
Carbon Monoxide High Range NDIR	0.1%	±5% or reading from 0.1% to 10%	0 - 10%
Hydrogen Sulphide (optional)	1ppm	±5ppm<100ppm ±5%>100ppm	0 - 200ppm
Nitric Oxide (optional)	1ppm	±5ppm<100ppm ±5%>100ppm	0 - 5000ppm
Nitrogen Dioxide (optional)	1ppm	±5ppm<100ppm ±10ppm<500ppm	0 - 1000ppm
Sulphur Dioxide (optional)	1ppm	±5ppm<100ppm ±5%>100ppm	0 - 5000ppm
Carbon Dioxide NDIR	0.1%	±0.3% reading	0 - 20%
Hydrocarbon NDIR	1ppm	+/- 5% of reading or +/- 12ppm volume	0 - 5000ppm Over-range: 10,000ppm

SPECIFICATIONS CONTINUED

Calculations *2			
Losses	0.1%	±1.0% reading	0 - 99.9%
Poison Index	0.1%	±0.01	0 - 99.99
Carbon Dioxide	0.1%	±0.3% Volume	0 - 20%
CO/CO2 Ratio	0.0001	±5% of reading	0 - 0.9999
Efficiency (Net or Gross)	0.1%	±1% of reading	0 - 99.9%
Efficiency High (C)	0.1%	±1% of reading	0 - 119.9%
Excess Air	0.1%	±0.2% of reading	0 - 119.9%
Pre-programmed Fuels			
UK	Natural Gas, Kinsale Gas, Natural Gas L, Town Gas, Gas Cor, Propane, LPG, Butane, Light Oil, Digester Gas, Heavy Oil, Coal, Anthracite, Wood Pellets, Coke, 5x User defined fuels		
Battery Life	>6 hours from full charge		
Certification	KANE988 is independently tested and certified to EN50379 parts 1-3		
Operating Conditions			
Temperatures	0 - 45°C		
Humidity	15 to 90% RH, (non-condensing)		
Ambient Operating Range	-5°C to +50°C/10% to 90% RH non condensing		
Power Supply (battery charger)	Input: 110Vac/220 Vac nominal Output: 12 VDC off load		
Physical Characteristics			
Weight	Approx. 1.2kg		
Dimensions	240mm x 165mm x 65mm		

*1 Using dry gases at STP *2 Calculated

EU DECLARATON OF CONFORMITY

This declaration of conformity is issued under the sole responsibility of the manufacturer:-

Kane International Ltd.

Kane House, 11 Bessemer Road, Welwyn Garden City, Hertfordshire, AL10 1GF, UK.

Tel: + 1707 375550

Web: www.kane.co.uk

The KANE988 is in conformity with the relevant Union harmonization legislation below:

UK Directive	
The Electromagnetic Compatibility Regulations 2016 (EMC)	
The Restriction of the Use of Certain Hazardous Substances in Electrical and Electronic Equipment Regulations 2012 (RoHS)	
Electrical Equipment (Safety) Regulations 2016	
EU Directive	Title
2014/30EU	Electromagnetic Compatibility (EMC)
2011/65EU	Restriction of the use of certain hazardous substances in electrical and electronic equipment (EMC)
2014/35	Low Voltage Directive (LVD)

The following harmonised standards and technical specifications have been applied:

Certification

The KANE988 is independently tested and certified to EN50379 1-3

EMC

EN50270:2015

SAFETY

EN61010-1:2010

ROSH (UK & EU)

IEC62321-2:2013, IEC62321-1:2013, IEC62321-3-1:2013, IEC62321-5:2013,
IEC62321-4:2013, IEC62321-7-2:2017, IEC62321-7-1:2015, IEC62321-6:2015

Signed for on behalf of:-
01. July 2022



Kane International Ltd.

A handwritten signature in black ink, appearing to read 'P. Morrison'.

Paul Morrison
Engineering Manager

WHERE TO SEND YOUR ANALYSER

For annual recertification visit ueitest.com/service for details.

UEi Test Instruments
ISO/IEC 17025:2017 accredited service center
7601 E 88th Place
Indianapolis, IN 46256

1-800-547-5740

COLD WEATHER PRECAUTIONS

Do not leave your flue gas analyser in a cold place overnight.

Electronic devices that become cold suffer when taken into a warm place. Condensation may form causing performance degradation and permanent damage.

Analyser sensors are affected by condensation - When this happens, oxygen or carbon dioxide reading display as “-” & sensors may be permanently damaged.

If you think your analyser is affected by condensation or water ingress, leave running in a warm place with pump ‘ON’ sampling fresh air for a few hours - connect charger to avoid draining batteries.

If you still experience problems please call our Customer Service team on 0800 059 800 7am to 5pm any normal weekday.
normal weekday.

THIS PRODUCT CONFIRMS WITH THE FOLLOWING

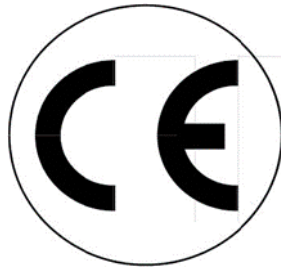

PLEASE RECYCLE

DISPOSAL



Caution: This symbol indicates that equipment and its accessories shall be subject to separate collection and correct disposal.

CLEANING:

Periodically clean your meters' case using a damp cloth. DO NOT use abrasive, flammable liquids, cleaning solvents, or strong detergents as they may damage the finish, impair safety, or affect the reliability of the structural components.

STORAGE:

Remove the batteries when instrument is not in use for a prolonged period of time. Do not expose to high temperatures or humidity. After a period of storage in extreme conditions exceeding the limits mentioned in the General Specifications section, allow the instrument to return to normal operating conditions before using it.

WARRANTY:

The KANE460 is warranted to be free from defects in materials and workmanship for a period of 1 year from the date of purchase. If within the warranty period your instrument should become inoperative from such defects, the unit will be repaired or replaced at UEI's option. This warranty covers normal use and does not cover damage which occurs in shipment or failure which results from alteration, tampering, accident, misuse, abuse, neglect or improper maintenance. Batteries and consequential damage resulting from failed batteries are not covered by warranty.

Any implied warranties, including but not limited to implied warranties of merchantability and fitness for a particular purpose, are limited to the express warranty. UEI shall not be liable for loss of use of the instrument or other incidental or consequential damages, expenses, or economic loss, or for any claim or claims for such damage, expenses or economic loss.

A purchase receipt or other proof of original purchase date will be required before warranty repairs will be rendered. Instruments out of warranty will be repaired (when repairable) for a service charge

For more information on warranty and service, contact:

www.ueitest.com Email: info@ueitest.com
1-800-547-5740

This warranty gives you specific legal rights. You may also have other rights, which vary from state to state.