

COA

Carbon Monoxide Analyzer

INSTRUCTION MANUAL
ENGLISH

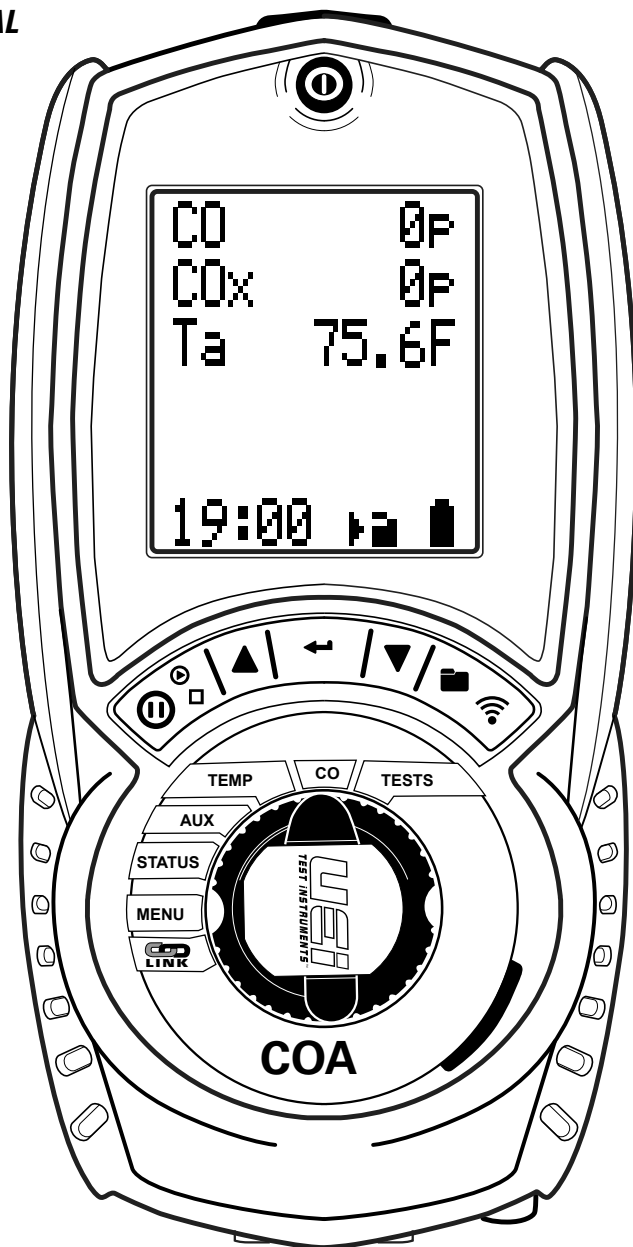

BACKED BY

UEI

SERVICE+

UP TO
10
YEAR
WARRANTY



FREE
SHIPPING
ON ANNUAL SERVICE



RoHS
Compliant

REACH
Compliant

TABLE OF CONTENTS

COA OVERVIEW	3
COA FEATURES & KEYPAD	4-6
FIRST TIME USE	7
FIT, REPLACE & CHARGE BATTERIES	7
POWER ON & QUICK START	8
SET UP YOUR ANALYZER - ROTATE DIAL TO MENU	8-15
SET UP OPTIONS	8
CHANGE ANALYZER SETTINGS	9
STATUS BAR OPTIONS	10
AUX - YOUR ANALYZER PERSONAL HOME SCREEN	11
TEMP - MEASURE TEMPERATURE	12
TEST - Appliance Sweep Test	13
TEST - Room CO Migration	12
TEST - Room Types	13
TEST - Testing A Room For CO & CO2	14-15
TEST - Kane  Link™ Simultaneous Multi Room Test	15
SEND, PRINT, STORE & MANAGE TESTS	16-18
SAMPLE TEST REPORTS	18-20
KANE LINK™ - ADD, MANAGE OR REMOVE WIRELESS DEVICES	20-21
KANE LINK™ - CONNECT TO KANE LIVE™ APP	22-24
GENERAL SAFETY	24-25
SPECIFICATIONS	26
USA ANNUAL RECERTIFICATION SERVICES	27
PRODUCT REGISTRATON	27
COLD WEATHER PRECAUTIONS	28
DISPOSAL	28
CLEANING	28
STORAGE	28
WARRANTY	28

Your analyzer measures:

- **Carbon Monoxide (CO)**
- **Differential Temperature**

Your analyzer performs:

- **Room CO & Sweep Tests**

Your analyzer is supplied with:

- Protective rubber sleeve with magnets for hands-free operation
- Flue gas sample probe with integral temperature sensor
- USB Battery charger & 3 NiMH rechargeable batteries
- Low flow detection to stop water entering analyzer
- Large 6 line display showing data & test results - Bottom line also displays analyzer status
- Test reports to send to an optional KANE infrared KANE printer or KANE LIVE™ App
- 45 log memory for any combination of Combustion, Aux, & Temperature tests
- Memory for 40 Room CO tests & 50 Sweep tests
- 2 lines of 24 characters to personalize with your details

HIGH CO LEVEL PROTECTION

Your analyzer is automatically protected from high levels of CO - When CO is above maximum range analyzer pump stops and CO purge pump starts.

Your analyzer displays - - - until CO levels fall below maximum range

KANE LINK™

Wirelessly connect optional KANE LINK™ devices to your KANE LINK™ analyzer - Once connected, they stay connected until you remove them.

When powered on, they replace or add to measurements your analyzer makes.

See section 11 to add manage or remove optional KANE LINK™ devices.

ANALYZER FRONT & BOTTOM

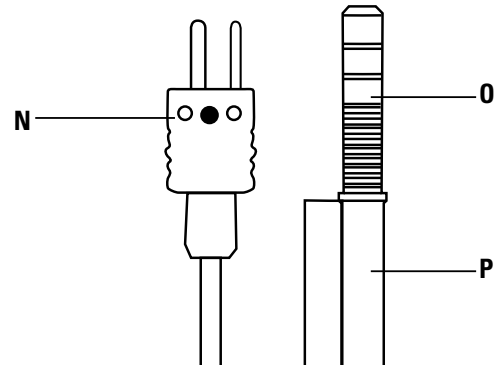
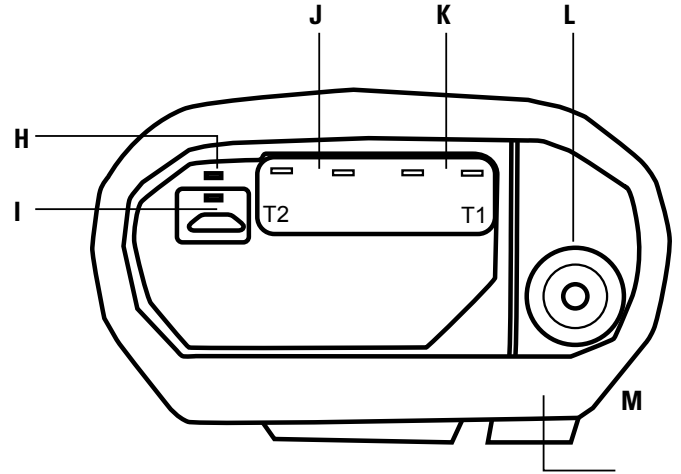
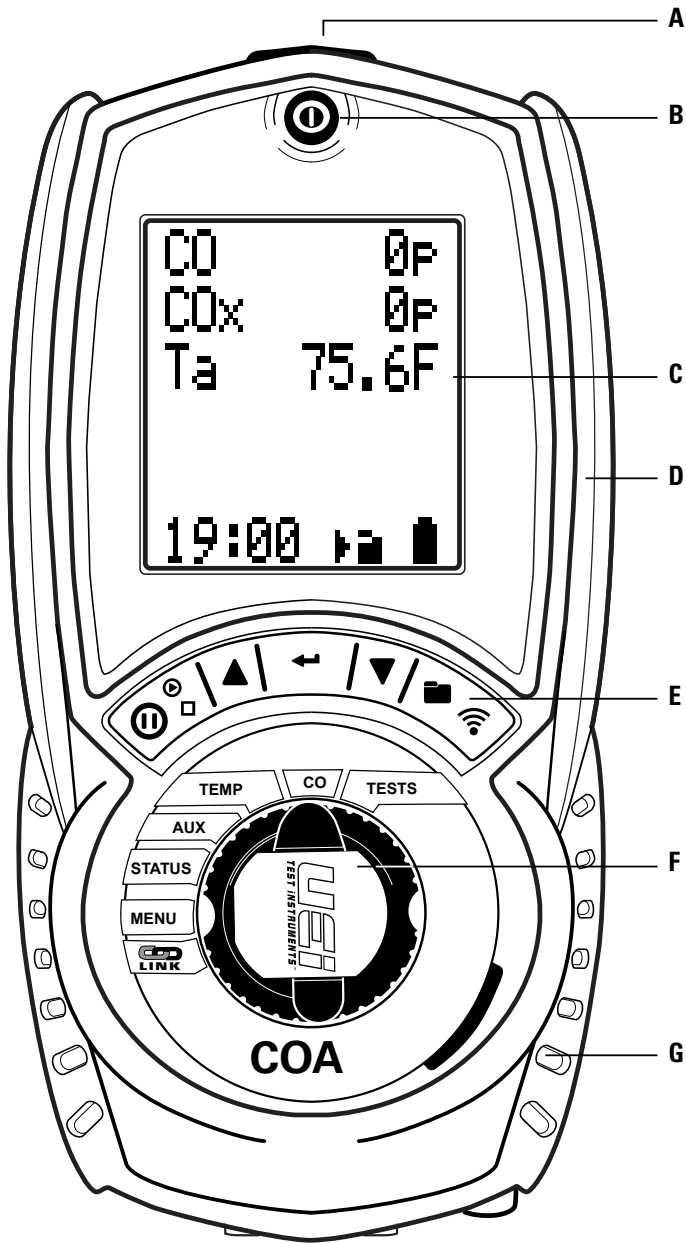

- A. Infrared printer emitter & torch
- B. Power On / Off
- C. 6 line display with backlight
- D. Protective rubber sleeve
- E. Keypad
- F. Rotary dial
- G. Water trap, particle filter & water stop filter

- J. Ambient temperature socket T2 -Differential
- K. Gas temperature socket T1
- L. Gas sample inlet
- M. Water trap drain with red plug
- N. Gas sample probe temperature plug -
Connect to Temperature T1
Narrow (+ve) pin must be on right side
- O. Red connector - Connect to gas sample inlet
- P. Gas sample probe hose

ANALYZER BACK & PROBE

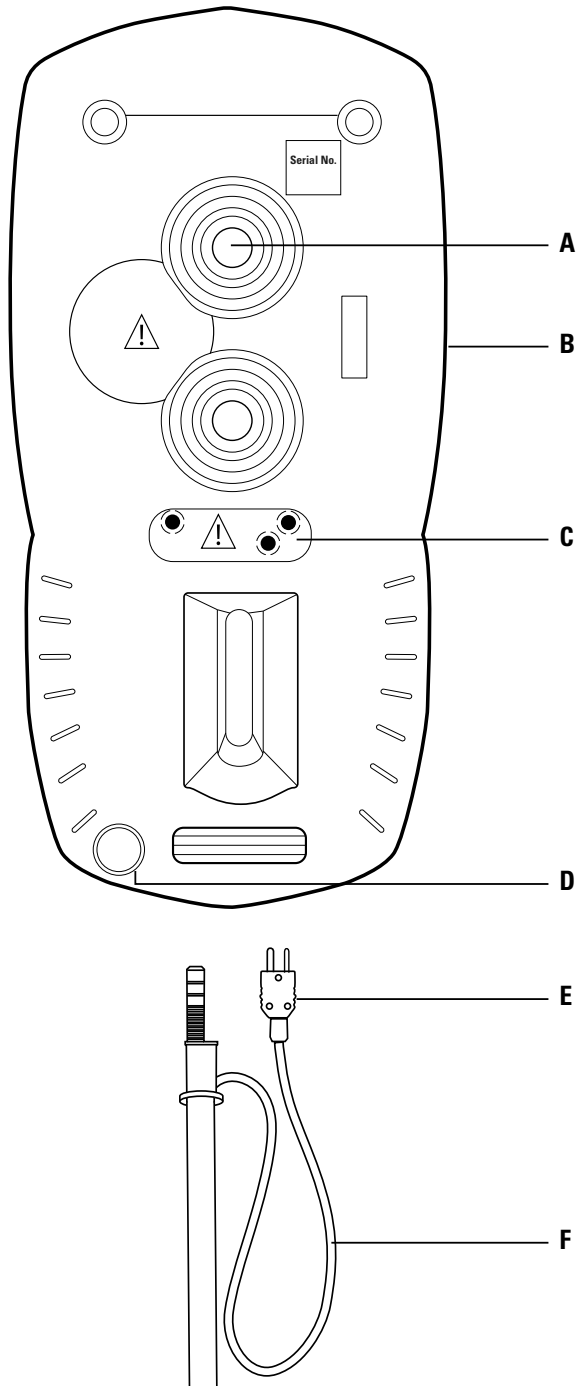

- A. Magnets x 2
- B. Protective rubber sleeve
- C. Gas sample exhaust ⚠ DO NOT COVER
- D. Water trap drain with red plug
- E. Gas sample probe temperature plug

- F. Gas sample probe temperature sensor cable
- G. Gas temperature probe sensor
- H Gas sample probe
- I. Gas sample probe depth stop cone
- J. Gas sample probe hose

KEYPAD & ROTARY DIAL - FROM LEFT TO RIGHT

KEYPAD

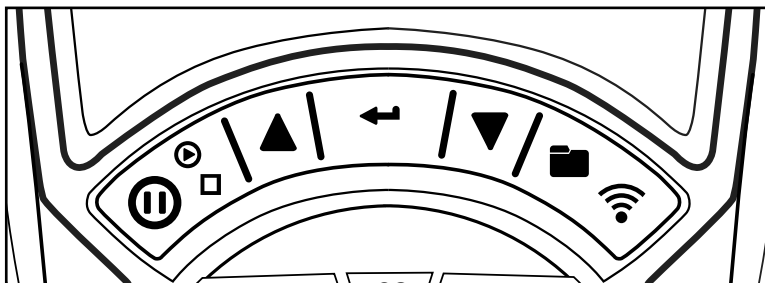

SYMBOL	FUNCTION
PUMP	Long press to turn pump on or off
	DATA HOLD - Short press to hold current data on screen - Short press again to return to readings
	NAVIGATE UP - Short press to scroll up
ENTER	ENTER - Press to select current option - also selects torch in some dial positions
	NAVIGATE DOWN - Short press to scroll down
	STORED LOG - Long press to store data
SEND	PRINT LOG - Short press to transfer a test result or log - Analyzer offers a destination choice

KEYPAD & ROTARY DIAL - FROM LEFT TO RIGHT

ROTARY DIAL

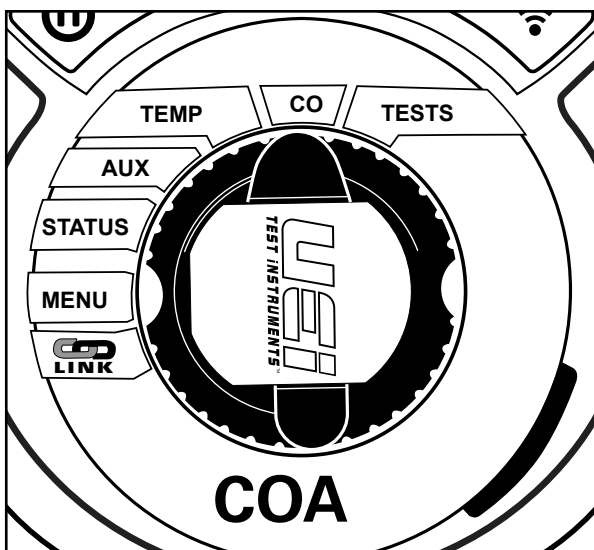

SYMBOL	FUNCTION
	Add, manage or remove KANE LINK™ devices & App settings - see section 1
MENU	Set up your Analyzer - see page 8
STATUS	View Analyzer status - see page 10
AUX	Personalize Analyzer display - see page 11
TEMP	Measure Temperature - see page 12
CO	Measure CO - see page 14
TESTS	Perform Sweep or Room CO Test - see page 15

FIRST TIME USE

Fit and charge your analyzer batteries for 8 hours
Power on & off your analyzer
Set up your analyzer to your requirements before use

FIT, REPLACE & CHARGE BATTERIES

BATTERY TYPE

Your analyzer uses rechargeable Nickel Material Hydride (NiMH) batteries.- Using other battery types may void your analyzer warranty.

WARNING

You can use Alkaline batteries but do not charge analyzer when fitted.
Do not mix NiMH cells with different capacities or from different manufacturers - All batteries must be identical.

FIT OR REPLACE BATTERIES

1. Turn over analyzer, remove protective rubber sleeve then remove battery compartment cover
2. Fit 3 NiMH "AA" rechargeable batteries with correct battery polarity
3. Replace battery compartment cover & protective rubber sleeve

UPDATE TIME AND DATE

Reset analyzer time & date after changing batteries.

NOTE: *Your analyzer STATUS bar displays current time, date and battery status - Time & date can only be changed when you have no stored logs in analyzer memory to protect integrity of stored logs.*

CHARGE NiMH BATTERIES

Your analyzer uses a standard Micro USB connector - For best results power off before connecting charger.

Charging indicator illuminates then powers off when charging is complete.

First charge for 8 hours - Thereafter NiMH batteries can be topped up any time.

If analyzer enters low power shutdown, 1 hour charge gives approx 2 hours continuous use.

BATTERY DISPOSAL

Always use approved disposal methods protecting the environment.

POWER ON & QUICK START

Your analyzer has 2 power on modes:

- Automatic zero calibration countdown - When measuring a gas
- Quick start - When measuring other parameters eg: temperature or pressure

To measure a gas, rotate dial to any position measuring gas - Your analyzer automatically starts a zero calibration countdown when powered on. Power on analyzer by pressing  button for 2 seconds.

NOTE: Always power on analyzer in fresh outdoor air when performing automatic zero calibration countdown.

NOTE: Connect gas probe hose to analyzer gas inlet and gas probe temperature plug to analyzer flue gas temperature socket T1.



To measure other parameters, rotate dial to any position not measuring gas e.g: **MENU, STATUS, TEMP / PRS** - Your analyzer automatically displays selected parameters

ANALYZER DISPLAY & OPERATION SUMMARY

Your analyzer displays 5 lines of tests & a status bar.

Display backlight illuminates for 10 seconds with each button press.

Rotate dial to the task or function you need to perform.

Navigate through options and menu choices using  &  then **ENTER**.

Button presses are either short or long

SET UP YOUR ANALYZER - ROTATE DIAL TO MENU

This section helps you set up your analyzer using the rotary dial & keypad.

SET UP OPTIONS

Rotate dial to MENU to see options

Press  &  to select option, then press **ENTER** when selected option is between the 2 arrows on screen.

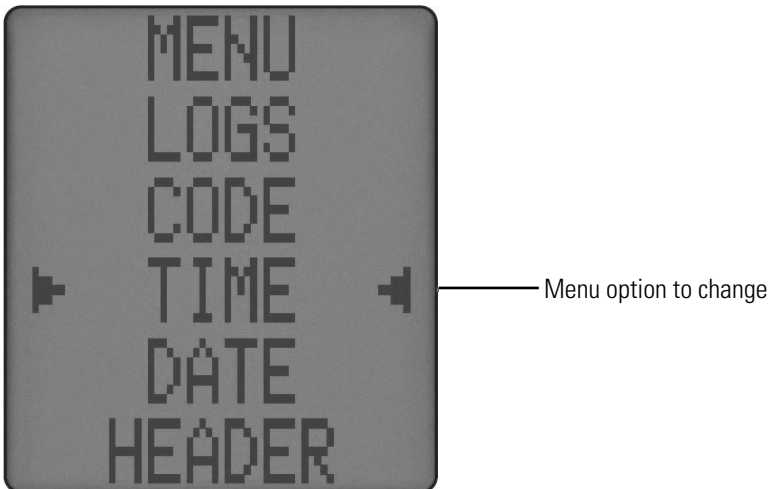

Press  or  to change option then press **ENTER** to confirm.

To exit **MENU** rotate dial to any position - Unsaved changes will be lost.

SET UP YOUR ANALYZER - ROTATE DIAL TO MENU (CONT.)

CHANGE ANALYZER SETTINGS

OPTION	YOUR CHOICE	NOTE
TIME	SET ANALYZER TIME	Press ENTER then ▲ or ▼ & ENTER to set HH:MM:SS NOTE: Only possible if memory logs empty
DATE	SET ANALYZER DATE	Press ENTER then ▲ or ▼ & ENTER to set DD:MM:YY NOTE: Only possible if memory logs empty
HEADER	SET ANALYZER PERSONALIZE ANALYZER HEADER DISPLAY & TEST REPORTS DATE	Personalize 2 lines of 24 characters - Press ENTER , then select line to edit with ▲ or ▼ & ENTER . Use & to select correct character then press ENTER To set HEADER via KANE LIVE™ app: Select CONTROLS on app Select ANALYZER HEADERS, Select LINE to edit Select SAVE to set header
PRINTER TYPE	SELECT KANE PRINTER	Press ENTER then ▲ or ▼ & ENTER to select KMIRP or IRP-2/3
LOGS	LOGS	View current memory usage & stored logs
C / F	CHANGE TEMPERATURE SCALE	Change the current temperature scale

NOTE: Your analyzer STATUS bar displays current time, date and battery status - Time & date can only be changed when you have no stored logs in analyzer memory to protect integrity of stored logs.

NOTE: You can use KANE LIVE™ APP to personalize analyzer header on display and test reports.

SET UP MENU CONTINUED

OPTION	YOUR CHOICE	NOTE
AIRFLOW	SET AIRFLOW SCALE	Select scale for DTHA2 airflow measurement
LANGUAGE	CHANGE LANGUAGE	Change analyzer language
UTIL	UTIL	Select UTIL to access utility menu - ▲ or ▼ & ENTER to select from: INFO - Shows analyzer firmware, wireless firmware & date next calibration due LEAK - Performs analyzer system leak test B'LIGHT - Selects backlight time from 15 to 300 seconds NOTE: Extending backlight time reduces battery life
CODE	CODE	Password protected for authorised service agents only - Default to 000000



USE YOUR ANALYZER - ROTATE DIAL FROM MENU

This section explains how to use your analyzer with the rotary dial & keypad.

STATUS BAR OPTIONS

Your analyzer status bar also offers options based on your current task.

Use ▲ or ▼ to view

	Always available - Display current analyzer status
	Always available - Displays current date
	Available in AUX position - See section 7.2 to change displayed readings on screen

NOTE: Your analyzer STATUS bar displays current time, date and battery status - Time & date can only be changed when you have no stored logs in analyzer memory to protect integrity of stored logs.

NOTE: You can use KANE LIVE™ APP to personalize analyzer header on display and test reports.

SET UP MENU CONTINUED

OPTION	YOUR CHOICE	NOTE
AIRFLOW	SET AIRFLOW SCALE	Select scale for DTHA2 airflow measurement
LANGUAGE	CHANGE LANGUAGE	Change analyzer language
UTIL	UTIL	Select UTIL to access utility menu - ▲ or ▼ & ENTER to select from: INFO - Shows analyzer firmware, wireless firmware & date next calibration due LEAK - Performs analyzer system leak test B'LIGHT - Selects backlight time from 15 to 300 seconds NOTE: Extending backlight time reduces battery life
CODE	CODE	Password protected for authorised service agents only - Default to 000000

AUX - YOUR ANALYZER PERSONAL HOME SCREEN

Rotate dial to AUX to view or change your home screen, change fuel and power on or off your analyzer torch.

You can change lines 1 to 5 of your analyzer AUX screen to display information you always want to see

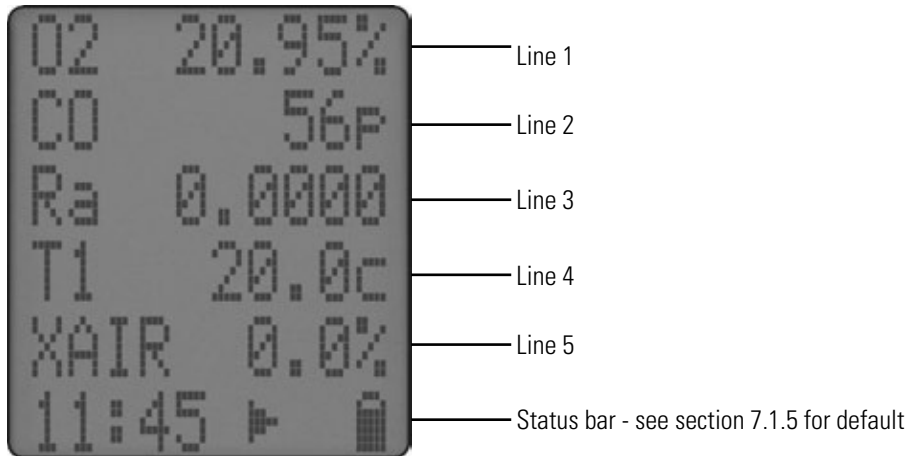

Change Your Screen

Press ▲ or ▼ until **EDIT** appears on status bar then long press **ENTER** until cursor flashes and line number appears in status bar.

Use ▲ or ▼ to select your parameter then press **ENTER** to store.

Repeat to change next line.

Power On / Off Torch

Press ▲ or ▼ to display time then press & hold **ENTER** until torch powers on / off.

NOTE: You can change fuel or power on / off torch in other rotary dial positions eg: AUX / CO.

TEMP - MEASURE TEMPERATURE

Temperature

Rotate dial to **TEMP** and connect your Type K temperature probe thermocouple plug to analyzer gas temperature socket T1 - See section 2 where to connect.

To measure differential temperature, connect another Type K temperature probe thermocouple plug to analyzer ambient temperature socket T2.

To measure flow & return temperature, use T1 for flow & T2 for return temperature.

If a probe is not connected to T2, analyzer internal temperature calculates net temperature.

See section 8 to send, print, store & manage tests.

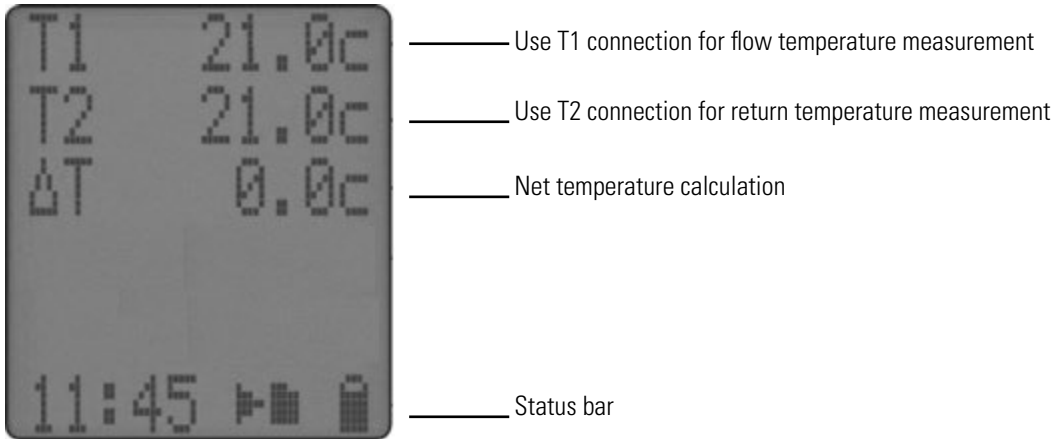

See section 8 to send, print, store & manage tests.

Co Section

Rotate dial to CO position to measure and view CO live values.

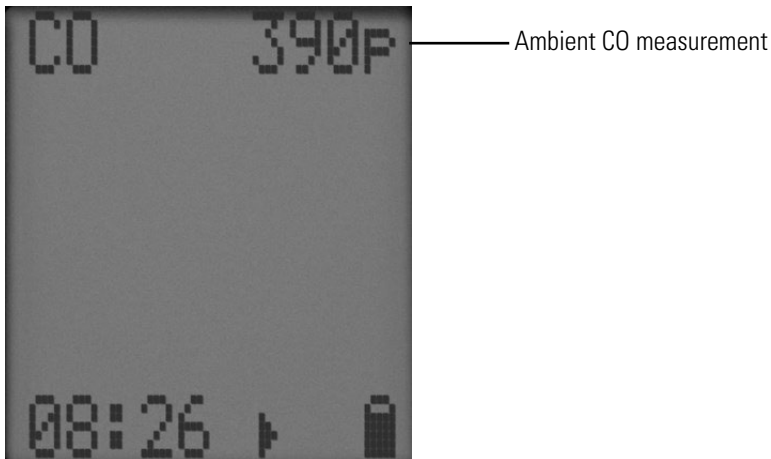

TEST MENU

Rotate dial to Tests to edit and specific tests.

Appliance Sweep Test

⚠ Appliance sweep tests are defined in UK standard BS7967 - You must be competent to perform these tests.

This will perform a 2 minute sweep test, once the test is started it will automatically measure ambient CO and ambient CO2 (if fitted).

On completion, your analyzer will automatically store in memory with a log number.

Send Sweep tests to your optional KANE-IRP3 printer by pressing ENTER or wirelessly to your KANE LIVE™ App using & ENTER.

Navigating Stored Tests



Select view from test option using ▲ or ▼ & ENTER to display most recent test
Long press ▲ or ▼ to navigate to previous tests

To delete room tests, rotate dial from room to any position then return.

Use ▲ or ▼ to select DEL ALL then press & hold ENTER to delete all room tests.

Room - CO Migration & Appliance Sweep Test

Rotate dial to **ROOM** to perform a CO migration test, an appliance sweep test or a simultaneous multiple room test

Rotate dial to **ROOM**, use ▲ or ▼ to select test from room test types in table in page 14 room test types then press ENTER and follow on screen instructions.

If fitted, ambient CO2 levels are also recorded.

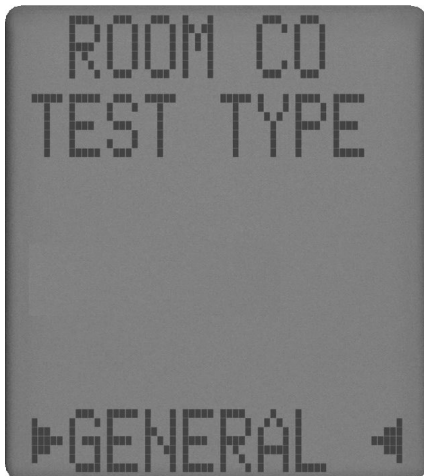

⚠ CO migration room tests are defined in UK standard BS7967 - You must be competent to perform these tests.

⚠ Appliance sweep tests are defined in UK standard BS7967 - You must be competent to perform these tests.

TEST

Room Test Types

Use ▲ or ▼ & ENTER to select test from these options:

TEST TYPE	DURATION	LIMITS / ALARM LEVELS
GENERAL	15 minute test with results stored every minute	LIMIT = 10ppm ALARM - 30ppm
SWEEP TEST	2 minute test with results stored every minute	LIMIT = 10ppm ALARM - 30ppm
MIGRATION TEST	15 minute test with results stored every minute	LIMIT = 10ppm ALARM - 30ppm
TYPE C SEALED APPLIANCE	15 minute test with results stored every minute	LIMIT = 10ppm ALARM - 30ppm
TYPE B BOILER OPEN FLUE	15 minute test with results stored every minute	LIMIT = 10ppm ALARM - 30ppm
TYPE A COOKER	30 minute test with results stored every minute	LIMIT = 10ppm ALARM - 30ppm
TYPE A WATER HEATER	5 minute test with results stored every minute	LIMIT = 10ppm ALARM - 30ppm
TYPE A SPACE HEATER	30 minute test with results stored every minute	LIMIT = 10ppm ALARM - 30ppm

Testing A Room For CO & CO2

When you start a room test your analyzer automatically measures ambient CO - It also measures ambient CO2 if fitted.

CO ONLY

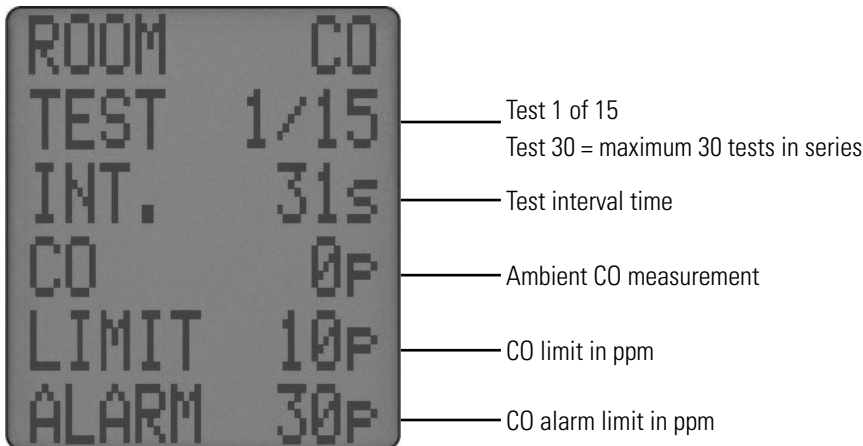

TEST

Testing A Room For CO & CO2

CO & CO2

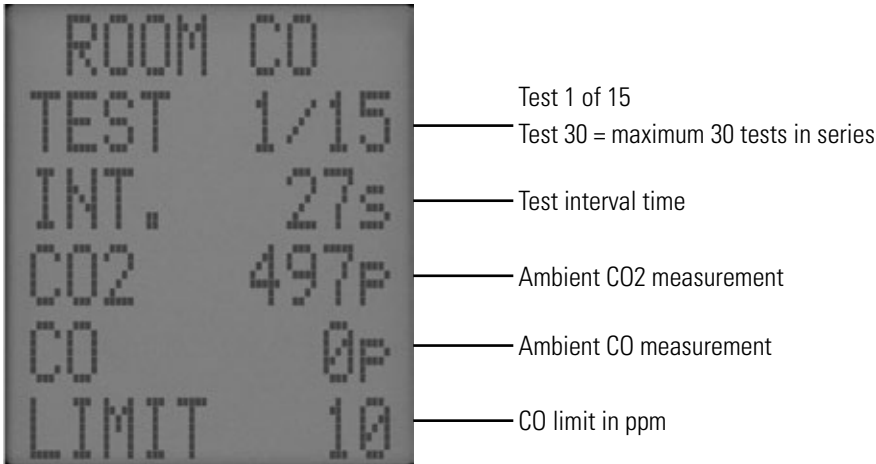

You can stop a **ROOM** test any time by pressing **ENTER**.

Otherwise it automatically stops after the pre-set time.

ROOM tests are automatically stored in memory with a log number.

Send **ROOM** tests to your optional KANE-IRP3 printer by pressing **ENTER** or wirelessly to your KANE LIVE™ App using ▲ & **ENTER**

NAVIGATING STORED TESTS



To delete room tests, rotate dial from room to any position then return.

Use ▲ or ▼ to select DEL ALL then press & hold **ENTER** to delete all room tests.

NOTE: Selecting DEL ALL deletes all stored Room tests.

Kane Link™ Simultaneous Multi Room Test

Your analyzer can test up to 4 room simultaneously with up to 4 optional COL CO monitors.

KANE LINK™ to add, manage or remove optional KANE LINK™ devices.

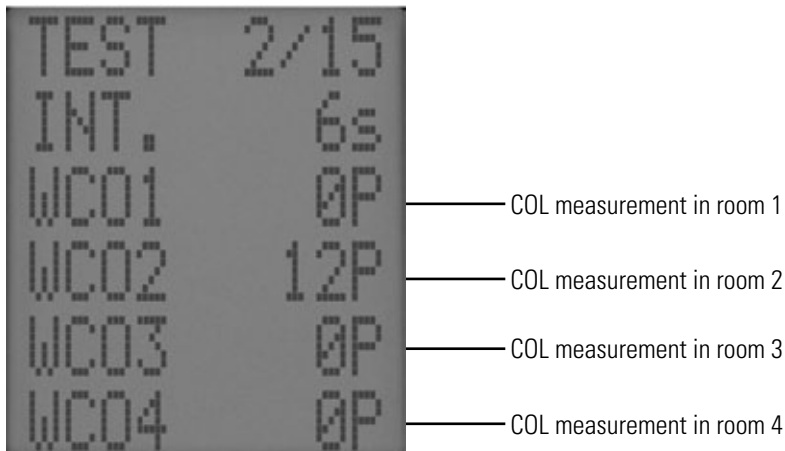

SEND, PRINT, STORE & MANAGE TESTS

This section explains how to manage your test results - in summary:

Short press **SEND** to send a test to your optional KANE-IRP3 printer or **KANE LIVE™** App.

Long press **SEND** for 2 seconds to store a test, called log.

SEND TO OPTIONAL KANE INFRARED PRINTER

To print test result or logs use optional KANE infrared printer.

Set printer type - See page 9

Power on printer and place printer infrared receiver in line with analyzer emitter - Allow 6 inch gap between analyzer infrared emitter & printer.

Short press **SEND** to transfer a test result or log - Analyzer offers a destination choice.

SEND TO KANE LIVE™

Ensure your analyzer is paired correctly to KANE LIVE™ - See page 22

Short press **SEND** to transfer a test result or log - Analyzer offers a destination choice.

ANALYZER MEMORY

Your analyzer stores up to 45 tests, called logs.

For example: combustion logs or any combination of combustion, Aux & Temperature logs up to 45.

Your analyzer also stores up to 40 Room CO tests and 50 Sweep tests called logs - To view, rotate dial to relevant test.

A logged data icon displays when your analyzer stores a test - see section 7.1.4 - Status Bar Icons

To view memory status, rotate dial to **MENU** then select **LOGS** using ▲ or ▼ & **ENTER**.

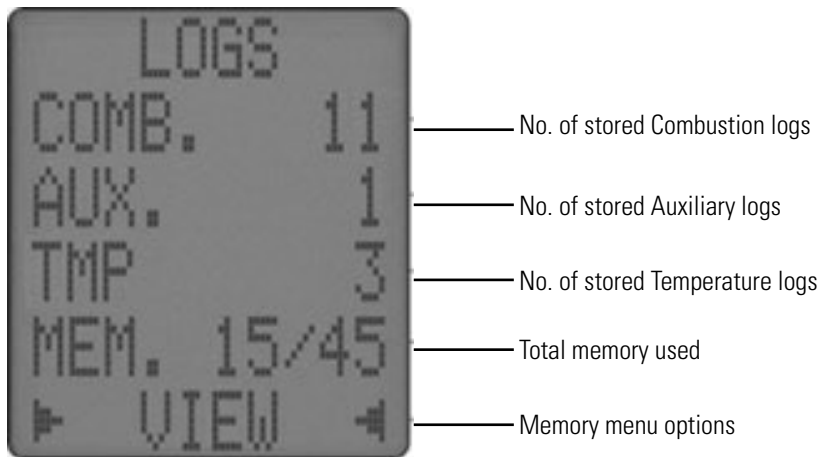

MEMORY MENU OPTIONS

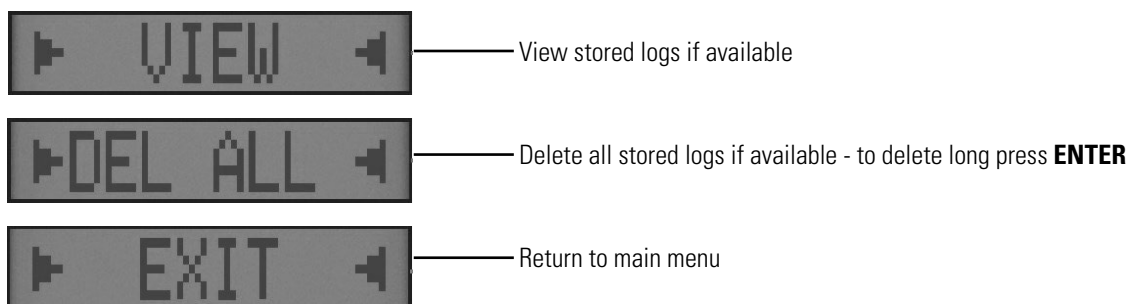

VIEW & MANAGE STORED LOGS

To view your test, select VIEW from LOGS Menu:

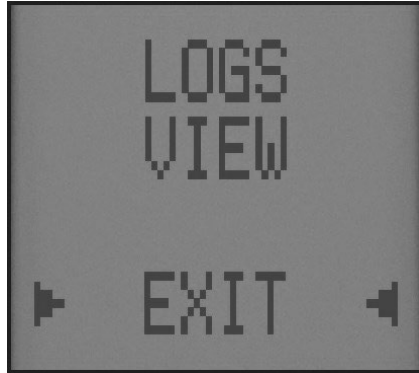

— List of available LOGS
— Navigate and select using ▲ or ▼ & ENTER

Select Log Type



— View Combustion Logs



— View Auxiliary Logs



— View Temperature Logs



— Return to previous menu

Select Log Stored

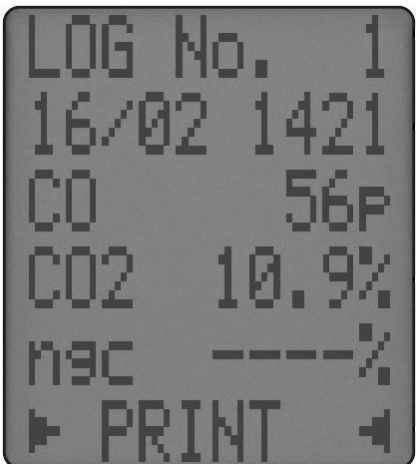

— LOG Number of that type

— Time & date of LOG

— Measurements & calculations specific to log type

— Navigation menu options

SEND, PRINT, STORE & MANAGE TESTS (CONT.)

SELECT LOG TYPE



Print current selected log



Navigate to next log



Navigate to previous log



Return to main menu

SAMPLE TEST REPORTS

Aux

Temperature

DTHA2

Measure

Sweep Test

<p>KANE KANE-COA1 SW00182 2.66</p> <p>COMPANY NAME TELEPHONE NUMBER</p> <p>SERIAL NO. 122621003</p> <p>LOG 03 DATE 16/08/24 TIME 11:14:15</p> <p>-----</p> <p>CAL DUE 13/08/25</p> <p>AUXILIARY</p> <p>FUEL NAT GAS CO ppm 0 COx ppm 137 T1 °C 49.8 T2 °C 22.7 NETT °C 27.1</p> <p>CUSTOMER</p> <p>APPLIANCE</p> <p>REFERENCE</p>	<p>KANE KANE-COA1 SW00182 2.66</p> <p>COMPANY NAME TELEPHONE NUMBER</p> <p>SERIAL NO. 122621003</p> <p>LOG 01 DATE 16/08/24 TIME 10:47:02</p> <p>-----</p> <p>CAL DUE 13/08/25</p> <p>TEMP.</p> <p>-----</p> <p>T1 °C 50.4 T2 °C 22.4 NETT °C 28.0</p> <p>CUSTOMER</p> <p>APPLIANCE</p> <p>REFERENCE</p>	<p>KANE KANE-COA1 SW00182 2.66</p> <p>COMPANY NAME TELEPHONE NUMBER</p> <p>SERIAL NO. 122621003</p> <p>LOG 02 DATE 16/08/24 TIME 10:12:56</p> <p>-----</p> <p>CAL DUE 13/08/25</p> <p>AUXILIARY</p> <p>DTHA2 V m/s 2.7 T °C 21.4 RH % 59.0</p> <p>CUSTOMER</p> <p>APPLIANCE</p> <p>REFERENCE</p>	<p>KANE KANE-COA1 SW00182 2.66</p> <p>COMPANY NAME TELEPHONE NUMBER</p> <p>SERIAL NO. 122621003</p> <p>LOG 02 DATE 16/08/24 TIME 11:16:22</p> <p>-----</p> <p>CAL DUE 13/08/25</p> <p>MEASURE</p> <p>-----</p> <p>CO ppm 15 Ta °C 23.1 ATM mbar 1008</p> <p>CUSTOMER</p> <p>APPLIANCE</p> <p>REFERENCE</p>	<p>KANE KANE-COA1 SW00182 2.66</p> <p>COMPANY NAME TELEPHONE NUMBER</p> <p>SERIAL NO. 122621003</p> <p>LOG 01 DATE 16/08/24 TIME 10:17:01</p> <p>-----</p> <p>CAL DUE 13/08/25</p> <p>SWEEP TEST</p> <p>-----</p> <p>CO LIMIT ppm 10 CO ALARM ppm 30 CO(Max) ppm 6</p> <p>CUSTOMER</p> <p>APPLIANCE</p> <p>REFERENCE</p>
---------------------------------------------------------------------------------------------------------------------------------------------------------------------------------------------------------------------------------------------------------------------------------------------------------------------------------------------------------------------------------------------------------------------------------------	--------------------------------------------------------------------------------------------------------------------------------------------------------------------------------------------------------------------------------------------------------------------------------------------------------------------------------------------------------------------------------------------------	----------------------------------------------------------------------------------------------------------------------------------------------------------------------------------------------------------------------------------------------------------------------------------------------------------------------------------------------------------------------------------------------	----------------------------------------------------------------------------------------------------------------------------------------------------------------------------------------------------------------------------------------------------------------------------------------------------------------------------------------------------------------------------------------------------	------------------------------------------------------------------------------------------------------------------------------------------------------------------------------------------------------------------------------------------------------------------------------------------------------------------------------------------------------------------------------------------------------------------

SAMPLE TEST REPORTS (CONT.)

Room Co Migration

KANE
KANE-COA1
SW00182 2.66

COMPANY NAME
TELEPHONE NUMBER

SERIAL NO. 122621003

LOG 07
DATE 16/08/24
TIME 14:56:12

CAL DUE 13/08/25

ROOM CO
MIGRATION

LIMIT	ppm	10
ALARM	ppm	30
TESTS		15

1 CO	ppm	9
2 CO	ppm	0
3 CO	ppm	0
4 CO	ppm	0
5 CO	ppm	0
6 CO	ppm	0
7 CO	ppm	0
8 CO	ppm	0
9 CO	ppm	0
10 CO	ppm	0
11 CO	ppm	0
12 CO	ppm	0
13 CO	ppm	0
14 CO	ppm	0
15 CO	ppm	0

CO(Max) ppm 9

CUSTOMER

APPLIANCE

REFERENCE

Room Co General

KANE
KANE-COA1
SW00182 2.66

COMPANY NAME
TELEPHONE NUMBER

SERIAL NO. 122621003

LOG 01
DATE 16/08/24
TIME 11:52:55

CAL DUE 13/08/25

ROOM CO
GENERAL

LIMIT	ppm	10
ALARM	ppm	30
TESTS		15

1 CO	ppm	0
2 CO	ppm	0
3 CO	ppm	0
4 CO	ppm	0
5 CO	ppm	25
6 CO	ppm	2
7 CO	ppm	5
8 CO	ppm	0
9 CO	ppm	0
10 CO	ppm	0
11 CO	ppm	0
12 CO	ppm	0
13 CO	ppm	0
14 CO	ppm	0
15 CO	ppm	0

CO(Max) ppm 25

CUSTOMER

APPLIANCE

REFERENCE

**Room Co
Type A Space Heater**

KANE
KANE-COA1
SW00182 2.66

COMPANY NAME
TELEPHONE NUMBER

SERIAL NO. 122621003

LOG 02
DATE 16/08/24
TIME 12:11:02

CAL DUE 13/08/25

ROOM CO
TYPE A
SPACE
HEATER

LIMIT	ppm	10
ALARM	ppm	30
TESTS		30

1 CO	ppm	0
2 CO	ppm	0
3 CO	ppm	0
4 CO	ppm	0
5 CO	ppm	0
6 CO	ppm	0
7 CO	ppm	0
8 CO	ppm	0
9 CO	ppm	0
10 CO	ppm	0
11 CO	ppm	22
12 CO	ppm	0
13 CO	ppm	0
14 CO	ppm	238
15 CO	ppm	4
16 CO	ppm	0
17 CO	ppm	0
18 CO	ppm	7
19 CO	ppm	0
20 CO	ppm	0
21 CO	ppm	0
22 CO	ppm	0
23 CO	ppm	0
24 CO	ppm	0
25 CO	ppm	0
26 CO	ppm	0
27 CO	ppm	0
28 CO	ppm	0
29 CO	ppm	0
30 CO	ppm	0

CO(Max) ppm 238

CUSTOMER

APPLIANCE

REFERENCE

**Room Co
Type A Cooker**

KANE
KANE-COA1
SW00182 2.66

COMPANY NAME
TELEPHONE NUMBER

SERIAL NO. 122621003

LOG 04
DATE 16/08/24
TIME 13:14:03

CAL DUE 13/08/25

ROOM CO
TYPE A
COOKER

LIMIT	ppm	30
ALARM	ppm	90
TESTS		30

1 CO	ppm	0
2 CO	ppm	0
3 CO	ppm	0
4 CO	ppm	0
5 CO	ppm	0
6 CO	ppm	0
7 CO	ppm	0
8 CO	ppm	0
9 CO	ppm	0
10 CO	ppm	0
11 CO	ppm	0
12 CO	ppm	29
13 CO	ppm	0
14 CO	ppm	0
15 CO	ppm	0
16 CO	ppm	0
17 CO	ppm	0
18 CO	ppm	0
19 CO	ppm	0
20 CO	ppm	0
21 CO	ppm	0
22 CO	ppm	0
23 CO	ppm	0
24 CO	ppm	0
25 CO	ppm	0
26 CO	ppm	0
27 CO	ppm	0
28 CO	ppm	0
29 CO	ppm	0
30 CO	ppm	0

CO(Max) ppm 29

CUSTOMER

APPLIANCE

REFERENCE

**Room Co
Type A Water Heater**

KANE
KANE-COA1
SW00182 2.66

COMPANY NAME
TELEPHONE NUMBER

SERIAL NO. 122621003

LOG 03
DATE 16/08/24
TIME 12:45:22

CAL DUE 13/08/25

ROOM CO
TYPE A
WATER
HEATER

LIMIT	ppm	10
ALARM	ppm	30
TESTS		5

1 CO	ppm	5
2 CO	ppm	0
3 CO	ppm	0
4 CO	ppm	0
5 CO	ppm	0

CO(Max) ppm 5

CUSTOMER

APPLIANCE

REFERENCE

**Room Co Type B Boiler
Open Flue**

KANE
KANE-COA1
SW00182 2.66

COMPANY NAME
TELEPHONE NUMBER

SERIAL NO. 122621003

LOG 05
DATE 16/08/24
TIME 14:02:29

CAL DUE 13/08/25

ROOM CO
TYPE B
BOILER
OPEN FLUE

LIMIT	ppm	10
ALARM	ppm	30
TESTS		15

1 CO	ppm	10
2 CO	ppm	0
3 CO	ppm	0
4 CO	ppm	0
5 CO	ppm	0
6 CO	ppm	0
7 CO	ppm	0
8 CO	ppm	0
9 CO	ppm	0
10 CO	ppm	0
11 CO	ppm	0
12 CO	ppm	0
13 CO	ppm	0
14 CO	ppm	0
15 CO	ppm	0

CO(Max) ppm 10

CUSTOMER

APPLIANCE

REFERENCE

**Room Co Type C
Sealed Appliance**

KANE
KANE-COA1
SW00182 2.66

COMPANY NAME
TELEPHONE NUMBER

SERIAL NO. 122621003

LOG 06
DATE 16/08/24
TIME 14:36:49

CAL DUE 13/08/25

ROOM CO
TYPE C
SEALED
APPLIANCE

LIMIT	ppm	10
ALARM	ppm	30
TESTS		15

1 CO	ppm	0
2 CO	ppm	0
3 CO	ppm	0
4 CO	ppm	0
5 CO	ppm	0
6 CO	ppm	0
7 CO	ppm	0
8 CO	ppm	0
9 CO	ppm	0
10 CO	ppm	0
11 CO	ppm	0
12 CO	ppm	0
13 CO	ppm	0
14 CO	ppm	0
15 CO	ppm	0

CO(Max) ppm 0

CUSTOMER

APPLIANCE

REFERENCE

**Room Co
Sweep Test**

KANE
KANE-COA1
SW00182 2.66

COMPANY NAME
TELEPHONE NUMBER

SERIAL NO. 122621003

LOG 08
DATE 16/08/24
TIME 15:14:05

CAL DUE 13/08/25

ROOM CO
SWEEP
TEST

LIMIT	ppm	10
ALARM	ppm	30
TESTS		1

1 CO	ppm	266
------	-----	-----

CO(Max) ppm 266

CUSTOMER

APPLIANCE

REFERENCE

SAMPLE SIMULTANEOUS MULTI ROOM TEST REPORTS

Multiroom reports are of individual reports for each room:

Room 1

```

KANE
KANE4585
SW00182 2.51
NAME
NUMBER
SERIAL NO. 122521054
LOG 01
DATE 27/09/22
TIME 14:19:43
-----
CAL DUE 01/01/17
-----
KANE79 CAL VALID
-----
ROOM CO
ROOM 1
-----
GENERAL
-----
LIMIT ppm 10
ALARM ppm 30
TESTS ppm 15
-----
1 WCO-1 ppm 0
2 WCO-1 ppm 0
3 WCO-1 ppm 0
4 WCO-1 ppm 0
5 WCO-1 ppm 0
6 WCO-1 ppm 0
7 WCO-1 ppm 0
8 WCO-1 ppm 0
9 WCO-1 ppm 0
10 WCO-1 ppm 0
11 WCO-1 ppm 0
12 WCO-1 ppm 0
13 WCO-1 ppm 0
14 WCO-1 ppm 0
15 WCO-1 ppm 0
-----
WCO-1(Max) ppm 0
-----
CUSTOMER
-----
APPLIANCE
-----
REFERENCE
-----
    
```

Room 2

```

KANE
KANE4585
SW00182 2.51
NAME
NUMBER
SERIAL NO. 122521054
LOG 02
DATE 27/09/22
TIME 14:19:43
-----
CAL DUE 01/01/17
-----
KANE79 CAL VALID
-----
ROOM CO
ROOM 2
-----
GENERAL
-----
LIMIT ppm 10
ALARM ppm 30
TESTS ppm 15
-----
1 WCO-2 ppm 0
2 WCO-2 ppm 12
3 WCO-2 ppm 14
4 WCO-2 ppm 13
5 WCO-2 ppm 7
6 WCO-2 ppm 3
7 WCO-2 ppm 0
8 WCO-2 ppm 0
9 WCO-2 ppm 0
10 WCO-2 ppm 0
11 WCO-2 ppm 0
12 WCO-2 ppm 0
13 WCO-2 ppm 0
14 WCO-2 ppm 0
15 WCO-2 ppm 0
-----
WCO-2(Max) ppm 14
-----
CUSTOMER
-----
APPLIANCE
-----
REFERENCE
-----
    
```

Room 3

```

KANE
KANE4585
SW00182 2.51
NAME
NUMBER
SERIAL NO. 122521054
LOG 03
DATE 27/09/22
TIME 14:19:43
-----
CAL DUE 01/01/17
-----
KANE79 CAL VALID
-----
ROOM CO
ROOM 3
-----
GENERAL
-----
LIMIT ppm 10
ALARM ppm 30
TESTS ppm 15
-----
1 WCO-3 ppm 0
2 WCO-3 ppm 0
3 WCO-3 ppm 0
4 WCO-3 ppm 0
5 WCO-3 ppm 0
6 WCO-3 ppm 0
7 WCO-3 ppm 0
8 WCO-3 ppm 0
9 WCO-3 ppm 0
10 WCO-3 ppm 0
11 WCO-3 ppm 0
12 WCO-3 ppm 0
13 WCO-3 ppm 0
14 WCO-3 ppm 0
15 WCO-3 ppm 0
-----
WCO-3(Max) ppm 0
-----
CUSTOMER
-----
APPLIANCE
-----
REFERENCE
-----
    
```



Room 4

```

KANE
KANE4585
SW00182 2.51
NAME
NUMBER
SERIAL NO. 122521054
LOG 04
DATE 27/09/22
TIME 14:19:43
-----
CAL DUE 01/01/17
-----
KANE79 CAL VALID
-----
ROOM CO
ROOM 4
-----
GENERAL
-----
LIMIT ppm 10
ALARM ppm 30
TESTS ppm 15
-----
1 WCO-4 ppm 0
2 WCO-4 ppm 0
3 WCO-4 ppm 0
4 WCO-4 ppm 0
5 WCO-4 ppm 0
6 WCO-4 ppm 8
7 WCO-4 ppm 8
8 WCO-4 ppm 0
9 WCO-4 ppm 0
10 WCO-4 ppm 0
11 WCO-4 ppm 0
12 WCO-4 ppm 0
13 WCO-4 ppm 0
14 WCO-4 ppm 0
15 WCO-4 ppm 0
-----
WCO-4(Max) ppm 8
-----
CUSTOMER
-----
APPLIANCE
-----
REFERENCE
-----
    
```

KANE LINK™ - ADD, MANAGE OR REMOVE WIRELESS DEVICES

Wirelessly connect optional KANE LINK™ devices to your KANE LINK™ analyzer - Once connected, they stay connected until you remove them. When powered on, they replace or add to measurements your analyzer makes.

To ADD, REMOVE and check STATUS of any KANE  LINK™ device, rotate dial to KANE LINK™ then select  using ▲ or ▼ & ENTER

KANE-WPCP2 PIPE CLAMP TEMPERATURE PROBES

To add, select WPCP2 using ▲ & ENTER.

Enter serial number using ▲ & ENTER. - Each serial number must be 10 digits long.

If longer use last 10 digits - e.g: in this example enter last 10 digits: 2105094301



KANE-DTHA2 ANEMOMETER

To add, select **DTHA2** using ▲ & **ENTER**.

Enter serial number using ▲ & **ENTER** - Each serial number must be 10 digits long.

If shorter enter 0's to make up to 10 - e.g: in this example enter 2001228 as 0002001228.

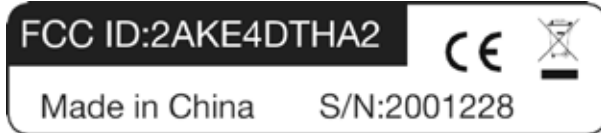

Other KANE LINK™ devices can be paired - Contact KANE for more details

COL PERSONAL & ROOM CO MONITOR

NOTE: Software may indicate **COL** or **KANE79** part numbers. These part numbers are interchangeable.

To add, select **COL** using ▲ & **ENTER**

Enter serial number using ▲ & **ENTER** - Each serial number must be 10 digits long.

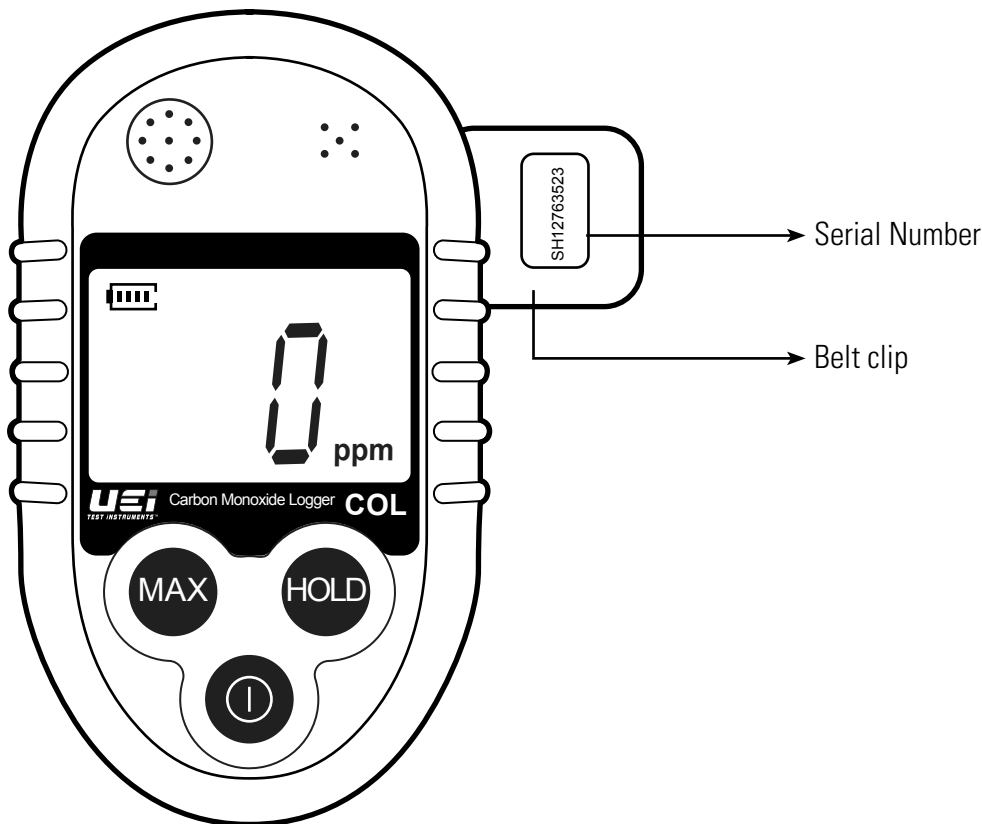

If shorter, enter 0's to make up to 10 - e.g: in this example enter J12345678 as 0012345678.

Other KANE LINK™ devices can be paired - Contact KANE for more details

KANE-DTHA2 ANEMOMETER

You can transfer test results to KANE LIVE™ APP or change analyzer header,

Downloaded or open KANE LIVE™

Rotate dial to KANE LINK™ then select APP using ▲ or ▼ & ENTER.

Tap CONNECT on KANE LIVE™ to find your analyzer - Select from device list then, if asked, tap PAIR to connect.

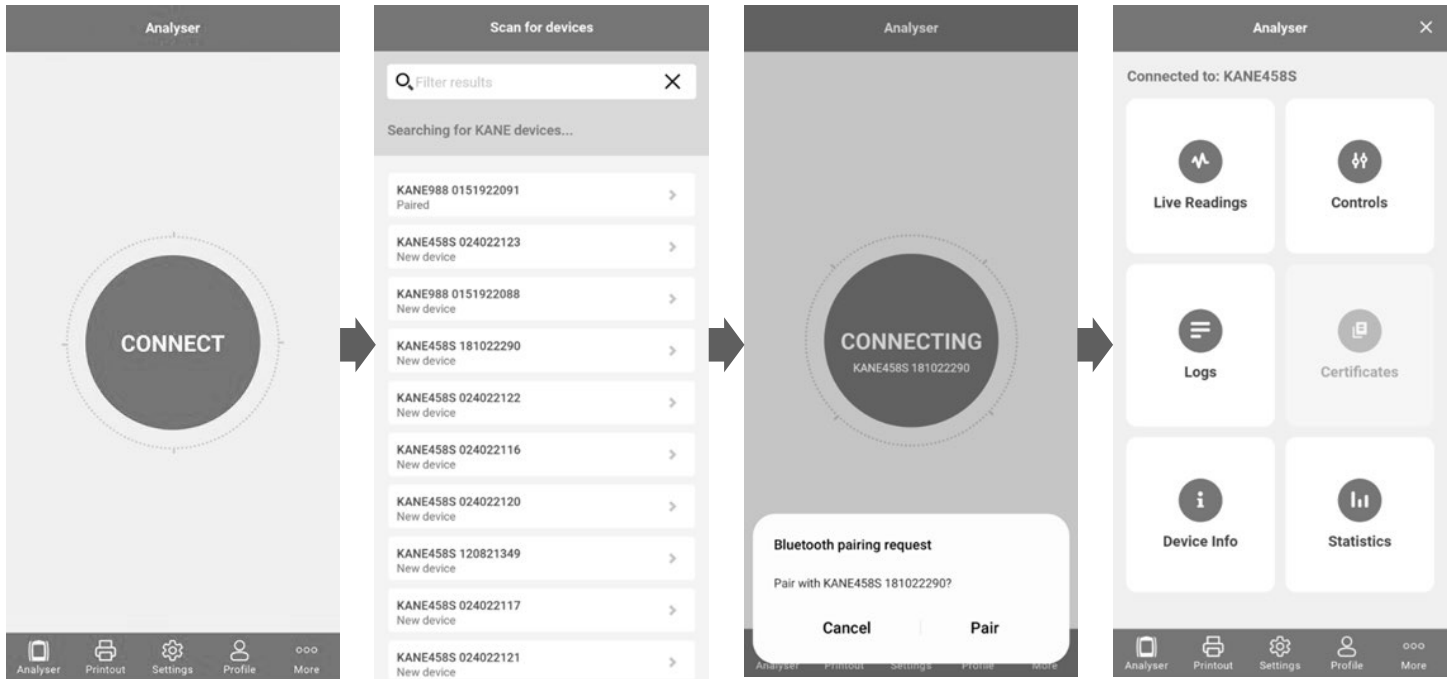

NECESSARY REGULAR MAINTENANCE

You must perform regular, simple and necessary maintenance to ensure your analyzer works correctly.

WATER TRAP, PARTICLE & WATER STOP FILTER

Some boilers produce high water vapor volume which can affect your analyzer.

Your analyzer has a water trap & particle filter with a hydrophobic filter inside the particle filter connected to a red filter carrier.

You must drain the analyzer water trap when you see water collecting in it.

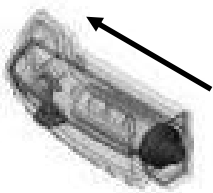

1) Remove water trap from your analyzer by pulling down

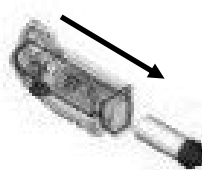

2) Remove filter cartridge

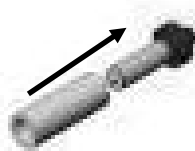

3) Remove WSF1 from particulate filter

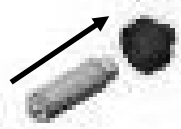

4) Remove the water trap to analyzer interface & discard contaminated WSF1 & replace with new one

Reassembly is the reverse of this procedure

KANE-DTHA2 ANEMOMETER

To drain:

1. Remove red plug
2. Empty water
3. Replace red plug

You must replace the particle & water stop filters when wet or dirty or when your analyzer displays LOW FLOW.

To replace:

1. Remove protective rubber sleeve and disconnect water trap
2. Remove red filter carrier with particle & water stop filter from water trap
3. Ensure water trap is completely dry
4. Attach new water stop & particle filter to red carrier
5. Insert red carrier in water trap and reconnect water trap to your analyzer.

Only use these replacement parts, available from authorized KANE partners or www.kane.co.uk

Water trap: SM50515

Particle filter: PF400/5 5 particle filters

Water Stop filter: WSF1/5 5 water stop filters

Red filter carrier: CM50302

GAS SAMPLE & TEMPERATURE PROBE

Always hang your probe to fully drain & dry.

You must check:

1. Your gas & temperature probe and tubing for cracks or leaks.
2. Your gas temperature probe is not bent or out of shape.
3. Your analyzer connectors are not bent or cracked.

 **WARNING** Never cool your gas sample probe in water or use probe shaft as a lever.

BATTERY CHARGER & BATTERIES

You must ensure your analyzer uses correctly charged & specified batteries.

See page 7 - FIT, REPLACE & CHANGE BATTERIES

ANALYZER & PROBE LEAK TEST

You must ensure your analyzer & probe have no leaks affecting measurement accuracy.

Your analyzer will perform a system integrity test to ensure no system leaks.

To perform, rotate dial to MENU then select UTIL by pressing or  or  & **ENTER**

Select LEAK by pressing  or  & **ENTER**

Follow analyzer instructions to connect and cover gas probe tip to ensure an air tight seal.

Select NEXT by pressing **ENTER**

Your analyzer system leak test then indicates pass or fail

ANALYZER & PROBE LEAK TEST

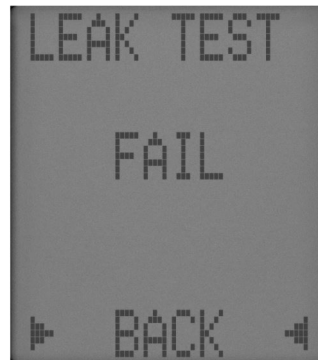

GENERAL SAFETY

 **SAFETY WARNING**

GASES

Your analyzer extracts combustion gases that are toxic in relatively low concentrations - They are exhausted from the bottom and rear of the analyzer.

This must only be used in well-ventilated locations by trained and competent persons after considering all potential hazards.

Conduct "bump" tests when verifying atmospheres are hazard free from - "Bump" check analyzer works by briefly exposing it to known gas mixtures to change readings by sensors in your analyzer.

NOTE: This is different from calibration when your analyzer is exposed to known gas mixtures then allowed to settle to a steady figure with readings adjusted to the known gas mixtures.

PROTECTION AGAINST ELECTRIC SHOCK (IN ACCORDANCE WITH 61010-1:2010):

This analyzer is designed as Class III equipment and should only be connected to SELV (Safety Extra Low Voltage) circuits.

The battery charger is designated as:

- Class II equipment
- Installation category II
- Pollution degree 2
- Indoor use only
- Altitude to 2000m
- Ambient temperature 0°C -40°C
- Maximum relative humidity 80% for temperatures up to 31°C decreasing linearly to 50%RH at 40°C
- Mains supply fluctuations not to exceed 10% of the nominal voltage

MEASURING GASES

After countdown is finished and your analyzer is correctly set up, put probe into appliance sampling point.

Probe tip should be in flue centre - use probe depth stop cone to set position.

With balanced flues, ensure probe is positioned far enough into flue so no air can "back flush" into probe.

⚠ SAFETY WARNING

Ensure flue probe handle does not get hot!

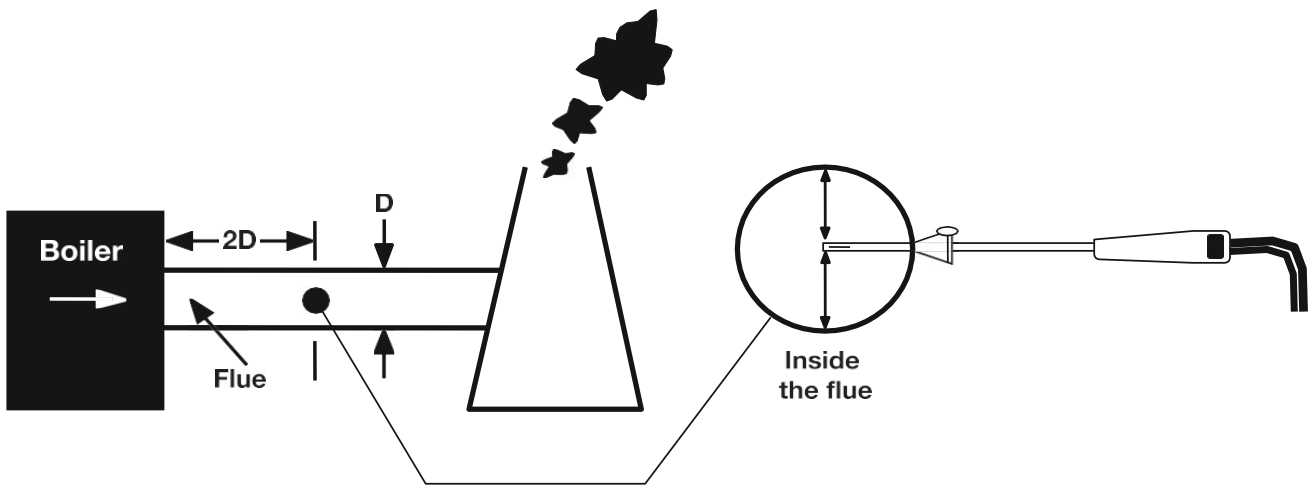

MEASURING GASES

Do not exceed analyzer operating specifications - In particular:

- Do not exceed probe maximum temperature (600°C)
- Do not exceed analyzer internal temperature operating range
- Do not put analyzer on hot surfaces
- Do not exceed water trap levels
- Do not let analyzer particle filter become dirty and blocked

Check readings are stable and within expected range.

SPECIFICATIONS

PARAMETER	RANGE	RESOLUTION	ACCURACY
Temperature & Pressure Measurement			
Flue Temperature	0 - 600°C	0.1°C	±0.5°C
Inlet temperature (Internal Sensor)	0 - 50°C	0.1°C	±1°C
Inlet temperature (External Sensor)	0 - 600°C	0.1°C	±0.5°C
Flue Gas Measurement			
Carbon Monoxide	0 - 2000ppm	1ppm	±3ppm or ±5% of reading (whichever is greater)
Carbon Monoxide H2 Compensated (If fitted)	0 - 10,000ppm	1ppm	±5ppm < 100ppm ±20ppm < 400ppm ±5% > 400ppm - 2000ppm ±10% > 2000ppm - 10,000ppm
Calculations			
Excess Air	0 -119.9%	0.1%	±0.2% of reading
Pre-programmed Fuels			
UK USA & France	Natural Gas, Propane, Butane, LPG, Light Oil, Wood Pellets		
Battery Life	>8 hours (continuous with pump on)		
Certification	The KANE-COA is independently test and certified to EN50379, Parts 1-3		
Operating Conditions			
Temperatures	0 - 45°C		
Humidity	15 to 90% RH, (non-condensing)		
Power Supply	Rechargeable batteries, USB Charging		
Physical Characteristics			
Weight	Approx. 0.625g		
Dimensions	216mm x 105mm x 45mm		

UK Directives

The Electromagnetic Compatibility Regulations 2016 (EMC)

The Restriction of the Use of Certain Hazardous Substances in Electrical and Electronic Equipment Regulations 2012 (RoHS)

Electrical Equipment (Safety) Regulations 2016

EU Directives

201430EU Electromagnetic Compatibility (EMC)

201165EU Restriction of the use of certain hazardous substances in electrical and electronic equipment (EMC)

2014/35 Low Voltage Directive (LVD)

Harmonised standards and technical specifications applied

EMC EN50270:2015

SAFETY EN61010-1:2010

ROSH (UK & EU) IEC62321-2:2013, IEC62321-1:2013, IEC62321-3-1:2013, IEC62321-5:2013, IEC62321-4:2013, IEC62321-7-2:2017, IEC62321-7-1:2015, IEC62321-6:2015



Complete Care for Your Combustion Analyzer.

BACKED BY



When you:

**Request Recertification or Service Online
Within 1 Year of Purchase or Last Service**

UEi will:

10 Year Warranty: All UEi combustion analyzers have a standard 1-year warranty. Each recertification extends the warranty for 1 more year for up to **10 years** from the date of purchase.

Contractors who book recertification of a C160 series analyzer at www.ueitest.com/service within 12 months from either the date of purchase or the date of the last recertification will receive reduced service pricing that lowers the cost of ownership and 2 additional benefits:

Same Day Service: All qualifying analyzers received for recertification through UEi Service+ are returned on the same business day.*

Free Shipping: UEi Service+ offers free shipping both to and from our service center. When customers book their recertification, they receive a prepaid UPS Ground shipping label.



*Analyzers that include the additional NO (Nitric Oxide) sensor requires 48-hour turnaround.

PRODUCT REGISTRATION

Register Online

Registering you analyzer online is quick and easy. Just log in or setup an account, it only takes a couple of minutes. Once logged in you can register you analyzer by providing some product information and uploading a proof-of-purchase.

When it's time to request recertification, just log into your account, select the analyzer, select the service and place your order.

COLD WEATHER PRECAUTIONS

Do not leave your monitor in a cold place overnight.

Electronic devices that become cold suffer when taken into a warm place.

Condensation may form affecting performance.

Sensors are affected by condensation or water. When this happens, readings may display as “-” & sensors may be permanently damaged.

If your monitor is affected by condensation or water ingress, leave in a warm place for a few hours.

If you still experience problems please contact UEi Customer Service.

DISPOSAL

Caution: This symbol indicates that equipment and its accessories shall be subject to separate collection and correct disposal.

CLEANING

Periodically clean your meters' case using a damp cloth. DO NOT use abrasive, flammable liquids, cleaning solvents, or strong detergents as they may damage the finish, impair safety, or affect the reliability of the structural components.

STORAGE:

Remove the batteries when instrument is not in use for a prolonged period of time. Do not expose to high temperatures or humidity. After a period of storage in extreme conditions exceeding the limits mentioned in the General Specifications section, allow the instrument to return to normal operating conditions before using it.

WARRANTY

The COA is warranted to be free from defects in materials and workmanship for a period of 1 year from the date of purchase. If within the warranty period your instrument should become inoperative from such defects, the unit will be repaired or replaced at UEi's option. This warranty covers normal use and does not cover damage which occurs in shipment or failure which results from alteration, tampering, accident, misuse, abuse, neglect or improper maintenance. Batteries and consequential damage resulting from failed batteries are not covered by warranty.

Any implied warranties, including but not limited to implied warranties of merchantability and fitness for a particular purpose, are limited to the express warranty. UEi shall not be liable for loss of use of the instrument or other incidental or consequential damages, expenses, or economic loss, or for any claim or claims for such damage, expenses or economic loss.

A purchase receipt or other proof of original purchase date will be required before warranty repairs will be rendered. Instruments out of warranty will be repaired (when repairable) for a service charge

For more information on warranty and service, contact:

www.ueitest.com Email: info@ueitest.com
1-800-547-5740

This warranty gives you specific legal rights. You may also have other rights, which vary from state to state.